

COVID-19

INTERIM PUBLIC HEALTH GUIDANCE TO REOPEN WORKFORCE

Public health guidance for industry leaders, organizations, and communities to reopen or expand current services within Livingston County. This guidance ensures the health and safety of employees, customers, and visitors.

LIVINGSTON COUNTY 
Health Department

May 22, 2020

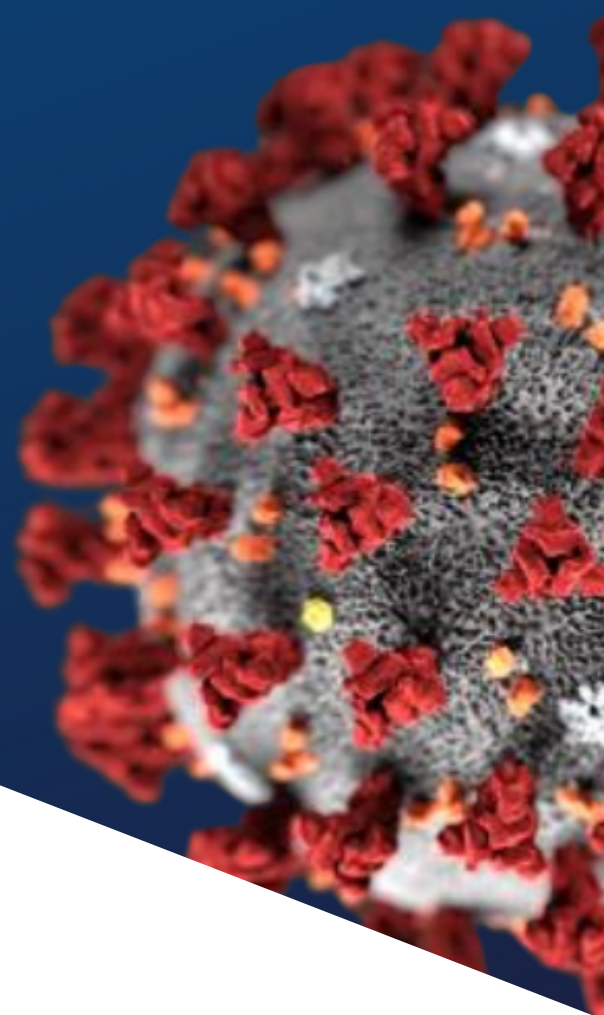

Table of Contents

- 3** Overview
- 4** MI Safe Start
- 16** What to Expect from Public Health
- 17** Prevention Overview for Improving Safety
- 18** Local Public Health Guidance
 - Businesses
 - Real Estate
 - Government
 - Manufacturing
 - Construction
 - Restaurants
 - Bars
 - Retail Establishments
 - Personal Services - Salons, Barbershops, Tattoo Parlors, Spas
 - Outdoor Activity - Recreation, Industry, Tourism
 - Healthcare Providers
 - Mass Gathering Areas - Libraries, Places of Worship, Community Centers
 - Childcare Programs
 - K-12 Schools
 - Colleges & Universities
 - Airports
 - Bus Transit
 - Rideshare: Taxi, Limo, Lyft, Uber
 - Senior Facilities
 - Vulnerable Workers
- 76** References
- 77** Resources
 - LCHD: COVID-19 self-monitoring booklet
 - MDHHS: Cleaning & disinfection after COVID-19 exposure
 - CDC: Use of face coverings to help slow the spread of COVID-19
- 91** Handouts for Employees
 - MDHHS: Frequently Asked Questions for face coverings
 - MDHHS: COVID-19 testing process
 - MDHHS: When is it safe to leave home?
 - CDC: How to protect yourself & others
- 99** Signs for Workplace
 - CDC: Germs all around you
 - CDC: Stop the spread of germs
 - CDC: Feeling sick?
 - LCHD: Face coverings must be worn

OVERVIEW

Note: This guidance will continue to evolve as more information is known and further Executive Orders are issued or change. It is expressly intended as a planning tool and recommended best practices. Executive Orders contain the requirements that must be met in order to operate. Some of these requirements will be universal, such as a COVID-19 Preparedness and Response Plan and some will be business type specific, for example, bars and restaurants. We will continue to keep this guidance current by adding a date to the cover and will post updates on our website. Current minimum requirements for businesses can be found under [EO 2020-96](#) and [EO 2020-97](#).

As Michigan begins the slow process of reopening after a long period of shutdown due to COVID-19, there is a large demand for guidance to support businesses, organizations, and communities. The Governor's office recently launched [MI Safe Start - A Plan to Re-Engage Michigan's Economy](#). MI Safe Start outlines the state's response for reopening each of its regions based on six phases of the epidemic. Now it is important that re-opening guidance is available for sectors within each community to plan and prepare to safely open when the time comes.

This guidance is designed to assist community and business sectors in developing plans for reopening. Businesses, organizations, and communities are expected to participate in the control of COVID-19 in partnership with local public health departments – this may involve providing testing, contact tracing, and issuing their own quarantine process immediately, rather than waiting for local public health guidance. When sectors begin to reopen, their ability to procure necessary supplies, such as face coverings, hand sanitizer, hand washing stations, gloves, etc., must be considered.

As with any guidance, please know that these are recommendations. Please consider reaching out to your legal counsel and liability insurance carrier for review and further guidance.

MI SAFE START

INTRODUCTION

We have made tremendous progress in fighting COVID-19 in Michigan. Our medical workers, first responders, and other critical workers have put their lives on the line for us every day, and we owe it to them to do whatever we can to stop the spread of the virus.

All of us know the importance of getting the economy moving again. We have already loosened some restrictions on landscaping, construction, and manufacturing. But the worst thing we could do is open up in a way that causes a second wave of infections and death, puts health care workers at further risk, and wipes out all the progress we've made.

We will keep listening to experts and examining the data here in Michigan to reduce deaths, keep our healthcare system from collapsing, and protect those working on the front lines.

Together, we will move forward.

Governor Gretchen Whitmer's MI Safe Start Plan outlines how we will begin to re-engage while continuing to keep our communities safe. Re-engagement will happen in phases. Those businesses that are necessary to protect and sustain life are already open. As we move into lower-risk phases, additional business categories will re-open and the restrictions on public gatherings and social interactions will ease.

As always, we will be guided by the facts in deciding whether to transition from one phase to another. We are looking at data every day to understand where we are: data that tells us where the epidemic is spreading, whether our hospitals and other health-care providers can safely cope with any surge in infections, and whether our public health system is up to the task of suppressing new outbreaks.

We need to keep working to expand testing and require people who test positive, or are close contacts of those who do, to self-isolate. Moving too fast without the tests we need could put Michigan at risk of a second wave of infections. The most important thing right now is to listen to the experts and follow the medical science.

We are also looking at the best available evidence on the risks that different business sectors present and the steps that can be taken to mitigate those risks and protect workers. Our Safe Start Plan has been guided by the state's top public health and university experts, and is based on input from a wide range of experts, including the CEOs of major Michigan companies, labor and union leaders, and small business owners around Michigan.

We must reopen gradually and safely. By proceeding incrementally, we can evaluate the effects of our decisions. If cases start to surge, we may need to tighten up again. If the disease is contained, we can keep relaxing. The MI Safe Start Plan will re-engage our economy carefully and deliberately to avoid a second wave of infections.

This will be a long process. Our ability to move forward depends on all of us and on our collective commitment to protecting ourselves and others—whether at home, at work, or anywhere else we go. We will always put the health and safety of Michiganders first.



MI SAFE START

MI SAFE START PLAN

	1 Uncontrolled growth	2 Persistent spread	3 Flattening	4 Improving	5 Containing	6 Post-pandemic
What's happening with the disease?	Increasing number of new cases every day, likely to overwhelm the health system	Continue to see high case levels with concern about health system capacity	Case growth is gradually declining	Cases, hospitalizations and deaths are clearly declining	Continued case and death rate improvements and outbreaks can be quickly contained	Community spread not expected to return
What do we need to do to stay safe?	Stay Home, Stay Safe: Strict social distancing, travel restrictions, face coverings, hygiene best practices, remote work	Stay Home, Stay Safe: Strict social distancing, travel reduction, face coverings, hygiene best practices, remote work	Safer at Home: Continued distancing, increased face coverings No gatherings	Safer at Home: Continued distancing, face coverings, safe workplace practices Small gatherings	Stay Safe: Adherence to new guidelines. Continued distancing, coverings, mitigated workplaces Increased size gatherings	Sufficient community immunity and availability of treatment
What work can we do? <i>(Examples)</i>	Critical infrastructure <ul style="list-style-type: none"> • First responders • Health care workers • Critical manufacturing • Food and agriculture • Essential retail (e.g., grocery) • Transportation 	Critical infrastructure Additional types of recreation allowed	Specified lower-risk businesses with strict workplace safety measures <ul style="list-style-type: none"> • Construction • Manufacturing • Real estate • Outdoor work 	Additional lower-risk businesses with strict safety measures <ul style="list-style-type: none"> • Other retail, with capacity limits • Offices, but telework required if possible 	Most businesses, with strict mitigation measures <ul style="list-style-type: none"> • Restaurants / bars • K-12 and higher ed. (live instruction) • Travel 	All businesses Events and gatherings of all sizes with new safety guidance and procedures Social distancing rules are relaxed and large events are permitted
What factors determine progression to next phase?	Analysis shows epidemic growth rates slowing Hospital and treatment capacity built, alternative care facilities established Infrastructure for crisis response and data systems to monitor progression are in place	Cases, deaths decline for extended period Monitor impact on vulnerable populations Sufficient health system capacity in place Improved testing, contact tracing and containment capacity	Cases and deaths decline more sharply, percent positivity decreasing Healthcare system capacity continues to strengthen Robust testing, contact tracing and containment protocols in place	Cases and deaths at low absolute rates per capita Health system capacity is very strong Robust testing, contact tracing and containment protocols in place	High uptake of an effective therapy or vaccine	

Note: This framing is being updated and refined as additional guidance from CDC and public health experts becomes available

It is also possible to move backwards if risk increases and if we stop adhering to safe practices

MI SAFE START

MICHIGAN ECONOMIC RECOVERY COUNCIL REPORTING REGIONS

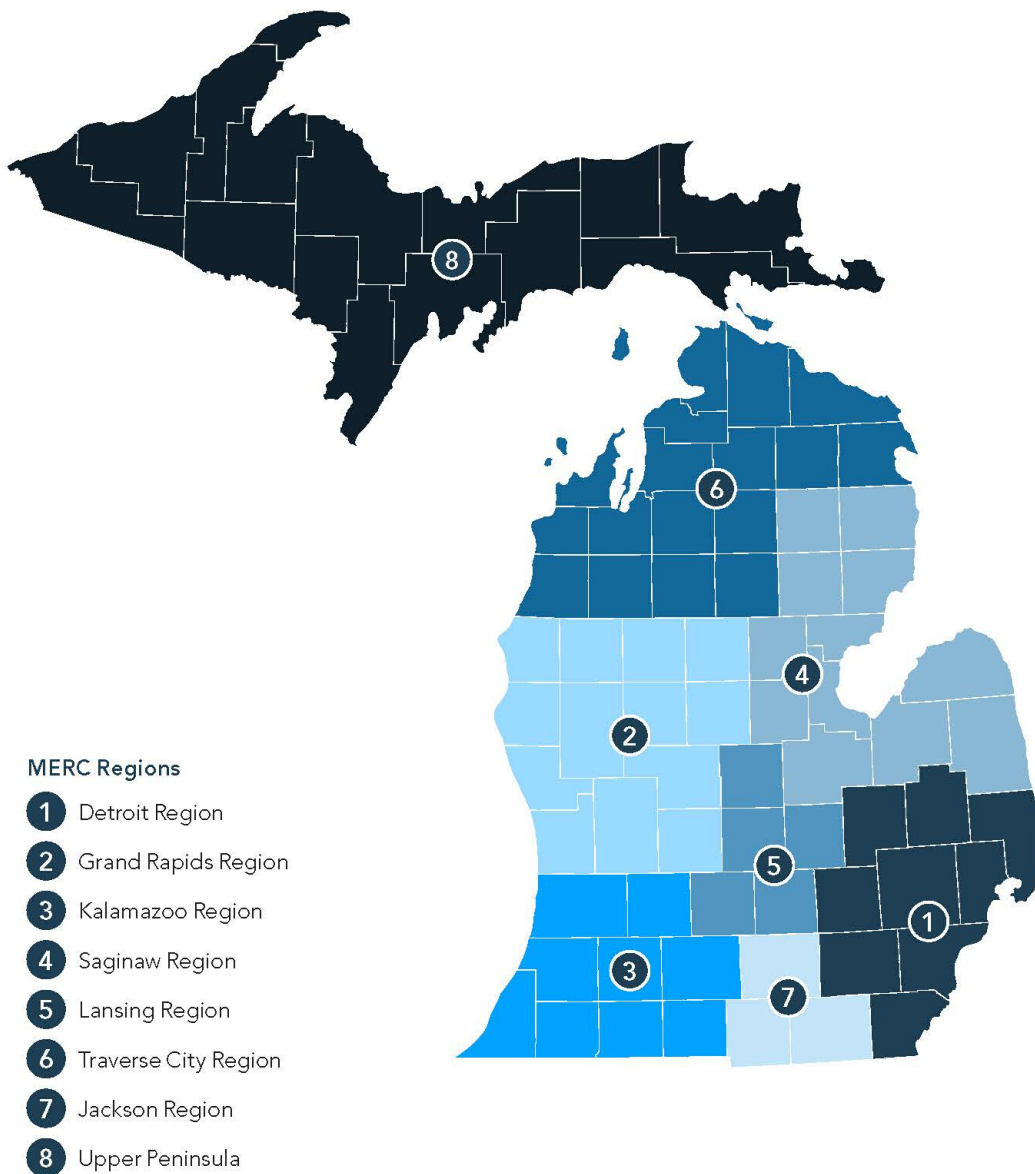

MI SAFE START

STAGES OF OUR RESPONSE

In Governor Whitmer's Safe Start Plan, we evaluate where the state and each of its regions are across six phases of this epidemic:

1. **Uncontrolled growth:** Increasing number of new cases every day, likely to overwhelm the health system. Only critical infrastructure remains open.
2. **Persistent spread:** Continue to see high case levels with concern about health system capacity. Only critical infrastructure remains open, with lower-risk recreational activities allowed.
3. **Flattening:** Epidemic is no longer increasing and health system capacity is sufficient for current needs. Specified lower-risk businesses can reopen given adherence to strict safety measures.
4. **Improving:** Epidemic clearly decreasing and health system capacity is strong with robust testing and contact tracing. Additional businesses can reopen given adherence to strict safety measures.
5. **Containing:** Epidemic levels are extremely low and outbreaks can be quickly contained. Health system capacity is strong with robust testing and tracing. Most businesses can reopen given adherence to strict safety measures.
6. **Post-pandemic:** Community spread is not expected to return (e.g., because of a vaccine) and the economy is fully reopened.

Assessing which phase we are in involves a comprehensive review of the facts on the ground. Guided by our experts, we are closely monitoring data that allows us to answer three questions:

- a. Is the epidemic growing, flattening, or declining?
- b. Does our health system have the capacity to address current needs? Can it cope with a potential surge of new cases?
- c. Are our testing and tracing efforts sufficient to monitor the epidemic and control its spread?

We have also worked with our best public health experts and the business community to assess the infection risks posed by workplaces across every sector of the economy. In general, those businesses that are likely to re-open sooner are those that present lower levels of infection risk and whose work cannot be performed remotely. We have also evaluated risk mitigation strategies to minimize the chance that any infection will spread at the workplace. Within each phase, businesses may reopen in a staggered manner to ensure safety. Finally, as our understanding of this disease improves, our assessments of what is appropriate in each phase could change to match the latest scientific evidence.

We are also establishing working groups to advise the state on how we can safely re-engage child care and summer camps, as well as businesses such as restaurants and bars, travel and tourism, and entertainment venues, so that when it is safe, there are best practices established for how to partially open in a low-risk manner.



MI SAFE START

PHASE 1: UNCONTROLLED GROWTH

What does it look like



The number of daily new cases increases by a constant rate every day, which leads to an increasingly accelerating case curve. If a community remains in this phase for an extended period of time, healthcare facilities could quickly be overwhelmed. Because unmitigated behavior contributes to the exponential growth, communities can slow the growth rate and exit this phase by introducing social distancing practices and wearing masks when in public.

What work can we do

What do we need to do to stay safe



Businesses and organizations

Only work that is necessary to protect or sustain life will be permitted

- **Retail:** Limited to grocery stores and other critical retail (e.g., pharmacies)
- **Public Transportation:** Permitted
- **Restaurants & Bars:** Available for take-out, delivery and drive-through only
- **Manufacturing:** Critical manufacturing only
- **Construction:** Only permitted for critical infrastructure projects
- **Food & Agriculture:** Permitted
- **Offices:** Closed to all non-critical workers during this phase
- **Education & Child Care:** Remote learning in K-12 and higher education, child care for critical workers

Personal and social

- **Social Distancing:** In place, maintain a six-foot distance from others when outdoors / in public
- **Face coverings:** Required
- **Gatherings:** Not permitted
- **Outdoor Recreation:** Walking, hiking, biking permitted
- **Quarantine/Isolation:** Individuals who have confirmed or suspected COVID-19 must isolate, and any individual with a known exposure must quarantine, according to CDC and public health guidance
- **At-risk populations:** All at-risk individuals should continue to shelter in place. Members of households with at-risk residents should be aware that by returning to work or other environments where distancing is not possible, they could carry the virus back home. Precautions should be taken to isolate from at-risk residents. Businesses should strongly consider special accommodations for personnel who are members of an at-risk population



MI SAFE START

PHASE 2: PERSISTENT SPREAD

What does it look like



This phase occurs after the Uncontrolled Growth phase, but when the epidemic is still expanding in the community. There are still high case levels, but the growth rate might gradually decrease. Within this phase, the epidemic is widespread in a community and source of infection is more difficult to trace. Even though the growth rate of new cases is decreasing, high volumes of infected individuals mean that health systems could become overwhelmed, leading to higher mortality rates. During this phase, it is important to maintain social distancing practices in order to slow the spread to a level that health systems can handle as they are continuing to build capacity.

What work can we do

What do we need to do to stay safe

Businesses and organizations

Only work that is necessary to protect or sustain life will be permitted

- **Retail:** Limited to grocery stores and other critical retail (e.g. pharmacies), plus curbside or delivery for nonessential retail
- **Public Transportation:** Permitted
- **Restaurants & Bars:** Available for take-out, delivery and drive-through only
- **Manufacturing:** Critical manufacturing only
- **Construction:** Only permitted for critical infrastructure projects
- **Food & Agriculture:** Permitted
- **Offices:** Closed to all non-critical workers during this phase
- **Education & Child Care:** Remote learning in K-12 and higher education, child care for critical workers

Personal and social

- **Social Distancing:** In place, maintain a six-foot distance from others when outdoors / in public
- **Face coverings:** Required
- **Gatherings:** Not permitted
- **Outdoor Recreation:** Walking, hiking, biking permitted. Additional recreation allowed, including golfing and motorboating
- **Quarantine/Isolation:** Individuals who have confirmed or suspected COVID-19 must isolate, and any individual with a known exposure must quarantine, according to CDC and public health guidance
- **At-risk populations:** All at-risk individuals should continue to shelter in place. Members of households with at-risk residents should be aware that by returning to work or other environments where distancing is not possible, they could carry the virus back home. Precautions should be taken to isolate from at-risk residents. Businesses should strongly consider special accommodations for personnel who are members of an at-risk population



MI SAFE START

PHASE 3: FLATTENING

What does it look like



This phase occurs when daily new cases and deaths remain relatively constant over a time period. Often, this occurs because communities have started to use social distancing practices and transmission rates have fallen to manageable levels. Because new cases are not constantly increasing, health system capacity has time to expand to epidemic needs and is not typically overwhelmed. During this phase, testing and contact tracing efforts are ramped up statewide. To prevent each infected individual from spreading the virus unchecked, rapid case investigation, contact tracing, and containment practices are necessary within a community.

What work can we do

What do we need to do to stay safe



Businesses and organizations

Non-critical businesses that pose lower risk of infection are able to open with increased safety measures during this phase:

- **Retail:** Limited to grocery stores and other critical retail (e.g. pharmacies), plus curbside or delivery for nonessential retail
- **Public Transportation:** Permitted
- **Restaurants & Bars:** Available for take-out, delivery and drive-through only
- **Manufacturing:** Permitted with additional safety measures and guidelines
- **Construction:** Permitted with additional safety measures and guidelines
- **Food & Agriculture:** Permitted
- **Offices:** Closed to all non-critical workers
- **Education & Child Care:** Remote learning in K-12 and higher education, child care for critical workers
- **Outdoor work:** Permitted with additional safety measures and guidelines

Personal and social

- **Social Distancing:** In place, maintain a six-foot distance from others when outdoors / in public
- **Face coverings:** Required
- **Gatherings:** Not permitted
- **Outdoor Recreation:** Walking, hiking, biking, golfing, boating permitted
- **Quarantine/Isolation:** Individuals who have confirmed or suspected COVID-19 must isolate, and any individual with a known exposure must quarantine, according to CDC and public health guidance
- **At-risk populations:** All at-risk individuals should continue to shelter in place. Members of households with at-risk residents should be aware that by returning to work or other environments where distancing is not possible, they could carry the virus back home. Precautions should be taken to isolate from at-risk residents. Businesses should strongly consider special accommodations for personnel who are members of an at-risk population



MI SAFE START

PHASE 4: IMPROVING

What does it look like



This phase occurs when the number of new cases and deaths has fallen for a period of time, but overall case levels are still high. When in the Improving phase, most new outbreaks are quickly identified, traced, and contained due to robust testing infrastructure and rapid contact tracing. Health system capacity can typically handle these new outbreaks, and therefore case fatality rate does not rise above typical levels. Though a community might be in a declining phase, the overall number of infected individuals still indicate the need for distancing to stop transmission and move to the next phase.

What work can we do

What do we need to do to stay safe

Businesses and organizations

Most business and organizations will be open throughout this phase under strict safety measures. These include:

- **Retail:** Permitted with additional safety measures and guidelines (e.g., limited capacity)
- **Public Transportation:** Permitted
- **Restaurants & Bars:** Available for take-out, delivery and drive-through only
- **Manufacturing:** Permitted with additional safety measures and guidelines
- **Construction:** Permitted with additional safety measures and guidelines
- **Food & Agriculture:** Permitted
- **Offices:** Open (remote work still required where feasible)
- **Education & Child Care:** Remote learning in K-12 and higher education, summer programs in small groups
- **Outdoor work:** Permitted with additional safety measures and guidelines

Personal and social

- **Social Distancing:** In place, maintain a six-foot distance from others when outdoors / in public
- **Face coverings:** Required
- **Gatherings:** Limited to small groups with social distancing
- **Outdoor Recreation:** Walking, hiking, biking, golfing, boating permitted. Activities permitted in small groups with social distancing
- **Quarantine/Isolation:** Individuals who have confirmed or suspected COVID-19 must isolate, and any individual with a known exposure must quarantine, according to CDC and public health guidance
- **At-risk populations:** All at-risk individuals should continue to shelter in place. Members of households with at-risk residents should be aware that by returning to work or other environments where distancing is not possible, they could carry the virus back home. Precautions should be taken to isolate from at-risk residents. Businesses should strongly consider special accommodations for personnel who are members of an at-risk population



MI SAFE START

PHASE 5: CONTAINING

What does it look like



During the Containing phase, new cases and deaths continue to decrease for an additional period of time. At this point, the number of active cases has reached a point where infection from other members of the community is less common. With widespread testing, positivity rates often fall much lower than earlier phases. Rapid case investigation, contact tracing, and containment strategies cause new cases to continue to fall. However, if distancing and other risk mitigation efforts are not continued, infections could begin to grow again because a permanent solution to the epidemic has not yet been identified.

What work can we do

What do we need to do to stay safe

Businesses and organizations

Most business and organizations will be open throughout this phase under strict safety measures. These include:

- **Retail:** Permitted with additional safety measures and guidelines (e.g., limited capacity)
- **Public Transportation:** Permitted
- **Restaurants & Bars:** Available for dine-in with additional safety measures and guidelines
- **Manufacturing:** Permitted with additional safety measures and guidelines
- **Construction:** Permitted with additional safety measures and guidelines
- **Food & Agriculture:** Permitted
- **Offices:** Open with additional safety measures and guidelines
- **Education & Child Care:** Live instruction in K-12 and higher education
- **Outdoor work:** Permitted with additional safety measures and guidelines

Personal and social

- **Social Distancing:** In place, maintain a six-foot distance from others when outdoors / in public
- **Face coverings:** Required wherever possible
- **Gatherings:** Increased but still limited-sized groups with social distancing
- **Outdoor Recreation:** All outdoor recreation allowed
- **Quarantine/Isolation:** Individuals who have confirmed or suspected COVID-19 must isolate, and any individual with a known exposure must quarantine, according to CDC and public health guidance
- **At-risk populations:** All at-risk individuals should continue to shelter in place. Members of households with at-risk residents should be aware that by returning to work or other environments where distancing is not possible, they could carry the virus back home. Precautions should be taken to isolate from at-risk residents. Businesses should strongly consider special accommodations for personnel who are members of an at-risk population



MI SAFE START

PHASE 6: POST-PANDEMIC

What does it look like



Reaching this phase would mean that community spread is not expected to return, because of sufficient community immunity and availability of treatment. Because of this, the number of infected individuals falls to nearly zero and the community does not typically experience this strain of the epidemic returning. All areas of the economy reopen, and gatherings of all sizes resume.

What work can we do

What do we need to do to stay safe



Businesses and organizations

All businesses and organizations open with some lasting safety requirements

Personal and social

Minimal to no lasting limitations on personal and/or social activities



MI SAFE START

CONTROLLING SPREAD IN THE WORKPLACE

There are best practices workplaces should follow, with different levels of importance depending on the industry. The proper implementation of these best practices will mitigate risk in the workplace and allow for a safe and sustained return to work. If workplaces fail to follow some or all of these guidelines, it may curb the state-wide progress toward the revitalization phase and result in a re-instating of stricter social limitations.

These best practices fall into five categories:

A. Access control: Implementing best practices to quickly identify and catalogue potential introductions of COVID-19 into the workplace

- Daily symptom diaries (mandatory questionnaires self-attesting to symptoms and contacts)
- On-site temperature checks
- Rapid diagnostic testing protocols
- Intake procedures for visitors
- Guidelines for delivery areas

B. Social distancing: Minimizing levels of close contact within the workplace to limit the spread of COVID-19 among workers

- Remote work (standards for who can work in person, social distancing guidelines for work from home)
- Restrictions on common instances of non-essential close contact (e.g., crowded conference rooms, cafeterias)
- Restriction on in-person meeting size
- Physical barriers between workspaces

C. Sanitation / Hygiene: Increasing both the frequency and vigor of common cleaning practices as well as implementing new ones to reduce the amount of time COVID-19 can live on surfaces

- Frequent disinfection / cleaning (facilities and equipment)
- Local exhaust ventilation
- HEPA filters on HVAC units
- Availability of hand-washing facilities
- Restrictions on shared tooling / machinery



MI SAFE START

D. PPE: Ensuring all employees have access to personal protective equipment to keep them from both contracting and transmitting the COVID-19 virus

- Masks to be worn whenever workers cannot consistently maintain six-feet of separation
- Gloves as necessary
- Face shields as necessary

E. Social distancing: Minimizing levels of close contact within the workplace to limit the spread of COVID-19 among workers

- Isolation protocols
- Notification protocols (HR, first responders, government authorities)
- Investigation standards
- Facility cleaning / shutdown procedure
- Quarantine and return-to-work guidelines



What to Expect from PUBLIC HEALTH

What happens when a positive case is identified at your facility?

1. A call from a local public health department will notify the employer of a positive case at the workplace. Depending on where the employee resides, this may be a different public health department than Mqt County. Local public health departments will follow-up with cases that live in their jurisdiction.
2. Public health will give the positive case (employee) isolation orders and exclude case (employee) from working.
3. Public health will request assistance from case (employee) and potentially employer to identify and possibly get in touch with workplace contacts (e.g. other employees, clients, visitors). Do not share case name, details or health information with others.
4. Public health will give quarantine notice to contacts which may exclude them from work and will ask contacts to monitor symptoms.

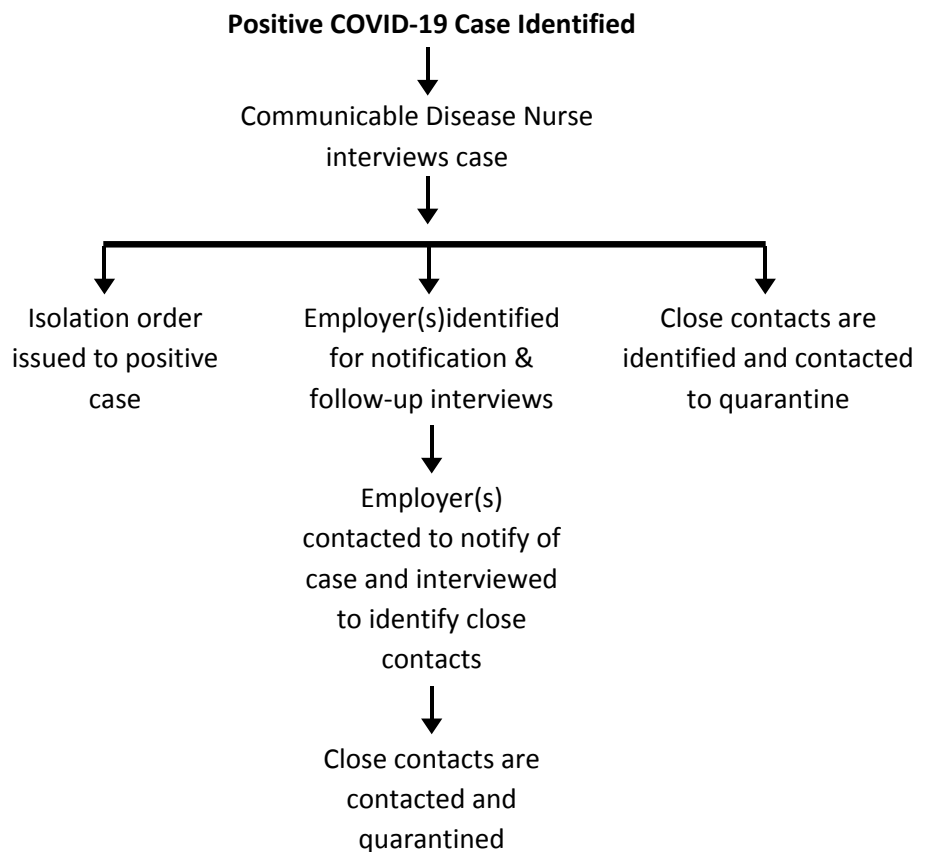

Communicable Disease case work is a critical function of public health. Confidentiality of personal information is essential. As part of a public health investigation, the local health department may ask for information about staff and other persons in connection with the case. This is routine public health practice and follows the Michigan Public Health Code 333.2433 & 333.2446:

To assure compliance with laws enforced by a local health department, the local health department may inspect, investigate, or authorize an inspection or investigation to be made of, any matter, thing, premise, place, person, record, vehicle, incident, or event. Section. 2241 to 2247 apply to an inspection or investigation made under this section.

Prevention Overview for **IMPROVING SAFETY**

When businesses, recreational activities, or social events resume, it is critical for these operations to have guidance on how to do so in a safe manner. COVID-19 is highly transmittable virus, and public health responses must attempt to prevent extensive, asymptomatic spread. While widespread testing and swift isolation and quarantine of those infected or exposed is important; due to resource constraints they are not as effective as social distancing.

- Develop an infectious disease preparedness and response plan
- Prepare to implement basic infection prevention measures
- Develop policies and procedures for prompt identification and isolation of sick people
- Develop, implement, and communicate about workplace flexibility and protections
- Implement workplace controls

Techniques for improved safety include physical distancing, engineering controls, administrative controls, and the use of personal protective equipment. Best-practice mitigation strategies are demonstrated in the diagram below.

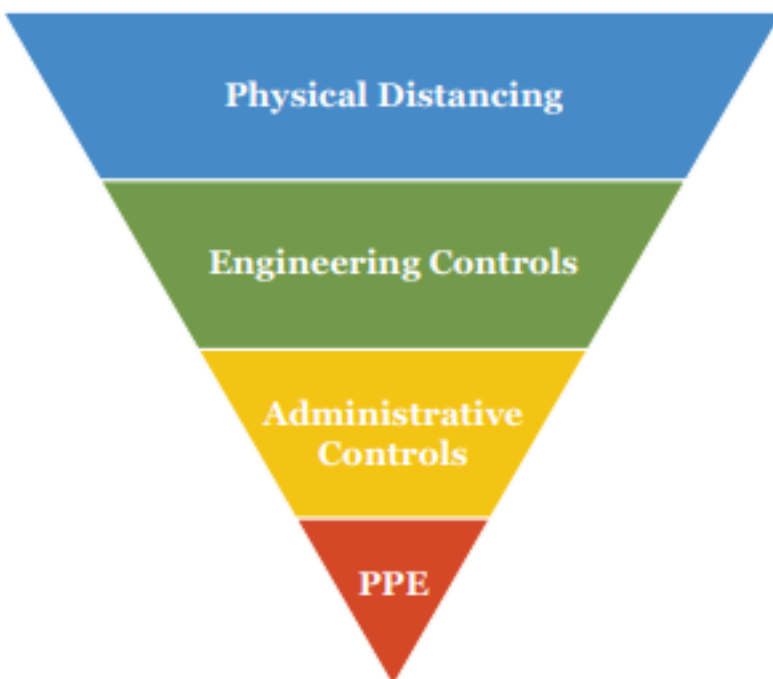

Until a vaccine or treatment is available, **SOCIAL DISTANCING** is crucial in preventing illness and death from COVID-19 within a community.

Physical Distancing

Wherever possible, have people work from home. This should include restructuring responsibilities to minimize the numbers of workers that need to be physically present

Engineering Controls

Create physical barriers between people, such as Plexiglas dividers or tape off seating

Administrative Controls

Redistribute responsibilities to reduce contact between individuals

Personal Protective Equipment (PPE)

Have people wear cloth face coverings

Local Public Health GUIDANCE FOR INDUSTRIES

This section provides local public health guidance for each of the following sectors in Livingston County jurisdiction. This guidance addresses the considerations needed before reopening. It is crucial also to follow all industry standards and adhere to licensing and regulatory guidelines as issued by your specific industry. Information about COVID-19 is rapidly changing. We are committed to providing reliable and accurate information throughout this pandemic.

Pg. Sector

19	Businesses
22	Real Estate
24	Government
27	Manufacturing
30	Construction
33	Restaurants
35	Bars
38	Retail Establishments
41	Personal Services - Salons, Barbershops, Tattoo Parlors, Spas
44	Outdoor Activity - Recreation, Industry, Tourism
47	Healthcare Providers
49	Mass Gathering Areas - Libraries, Places of Worship, Community Centers
53	Childcare Programs
56	K-12 Schools
59	Colleges & Universities
62	Airports
65	Bus Transit
68	Rideshare: Taxi, Limo, Lyft, Uber
70	Senior Facilities
74	Vulnerable Workers

Public Health Guidance for **BUSINESSES**

Administrative | Legal | Finance | Accounting



Conduct Risk Assessment

Establish critical protective guidelines. Consider the following questions:

- Are there locations where employees routinely congregate?
- Are tools and equipment frequently shared by multiple employees?
- Does customer flow allow for social distancing measures?
- Where are areas in your business that would not allow customers and staff to properly distance?
- Who are your high risk employees?
- Is your business actively engaged in activities that promote disease transmission?
- Does your business have existing cleaning and disinfecting procedures?
- How quickly can you communicate with employees?
- Are communication resources needed in multiple languages?



Physical Distancing

Establish policies and procedures for social distancing. Consider the following:

- Implement flexible worksites (e.g., telework), work hours (staggered shifts), and meeting and travel options (e.g. use video-/tele-conferencing for meetings, postpone non-essential meetings or events; travel separately).
- When video-/tele-conferencing is not possible, hold meetings in open, well-ventilated spaces where distancing is possible.
- Increase physical space between employees at the worksite, and between employees and customers – especially in waiting rooms. Install plastic shields between reception staff and visitors.
- Downsize operations.
- Deliver services remotely (e.g., phone, video, web).
- Deliver products through curbside pick-up or delivery.
- Limit the number of people in elevators, bathroom, meeting spaces, and other common spaces; consider reconfiguring office spaces and environment.
- Consider canceling, adjusting, or postponing large work-related meetings or gathering that can only occur in-person.



Engineering & Environmental Controls

Improve engineering controls and perform routine environmental cleaning.

Consider the following:

- Increase ventilation rates and percentage of outdoor air that circulates into the system.
- Support respiratory etiquette and hand hygiene for employees, customers, and visitors:
 - Provide tissues, no-touch disposal receptacles, and soap and water in the workplace (if not readily available, use alcohol-based hand sanitizer that is at least 60% alcohol). Ensure adequate supplies are maintained and place hand sanitizers in multiple locations.
 - Place posters that encourage hand hygiene to help stop the spread of COVID-19 at the entrance to your workplace and in other areas where they are likely to be seen.
 - Discourage handshaking – encourage the use of other non-contact methods of greeting.
 - Direct employees to visit CDC website for information on coughing and sneezing etiquette and handwashing.

Public Health Guidance for **BUSINESSES**

(continued)



Engineering & Environmental Controls (continued)

Improve engineering controls and perform routine environmental cleaning. Consider the following:

- Perform routine environmental cleaning and disinfection.
 - Routinely disinfect all frequently touched surfaces in the workplace, such as workstations, keyboards, telephones, handrails, and doorknobs.
 - For disinfection, most common EPA-registered household disinfectants should be effective. Follow the manufacturer's instructions for all cleaning and disinfection products.
- Discourage workers from using co-workers' phones, desks, offices, or other office tools and equipment, when possible. If they must use, provide disposable wipes so that commonly used surfaces (including doorknobs, remote controls, etc.) can be wiped down by between each use.
- Perform enhanced cleaning and disinfection after suspected cases of COVID-19 have been in the facility.



Administrative Controls

Establish administrative controls while employees and visitors are onsite. Consider the following:

- Identify a workplace coordinator who will be responsible for COVID-19 issues and their impact at the workplace.
 - Implement daily health and temperature screenings for employees upon arriving to work.
 - Provide education and training on new processes, COVID-19, and the use of PPE while in the workplace.
- Review Human Resource policies to make sure that policies and practices are consistent with both public health recommendations and existing state and federal workplace laws.
 - Implement flexible sick leave and supportive policies and practices.
 - Ensure that sick leave policies are flexible and consistent with public health guidance and provide employee training on new policies. If sick leave is not a benefit, it is recommended that the employer draft a non-punitive emergency sick leave policy.
 - Maintain flexible policies that permit employees to stay home to care for a sick family member or take care of children due to school/daycare closures.
 - Employers should not require a positive COVID-19 test result or a healthcare provider's note for employees who are sick to validate their illness, qualify for sick leave, or to return to work.
 - Connect employees to Employee Assistance Program (EAP) resources and community resources as needed. Employees may need additional social, behavioral, and other services for mental health support.
- Assess essential functions and the reliance that the community has on your services/products.
 - Be prepared to change your business practices, if needed, to maintain critical operations (e.g., identify alternative suppliers, prioritize existing customers, or temporarily suspend some of your operations if needed).
 - Identify alternate supply chains for critical goods and services as some may be in higher demand or unavailable.

Public Health Guidance for **BUSINESSES**

(continued)



Administrative Controls (continued)

**Establish administrative controls while employees and visitors are onsite.
Consider the following:**

- Assess essential functions and the reliance that others and the community have on your services/products (continued).
 - Talk with companies that provide your business with contract or temporary employees about the importance of sick employees staying home, and encourage them to develop non-punitive leave policies.
 - Talk with business partners about response plans. Share best practices with other businesses in your communities (especially in your supply chain), Chambers of Commerce, and associations to improve community response efforts.
 - Determine how you will operate if absenteeism spikes from increases in sick employees, those who stay home to care for sick family members, and those who must stay home to watch their children. Plan to monitor and respond to absenteeism in the workplace. Implement plans to continue your essential business functions. Prepare to institute flexible workplace and leave policies. Cross-train employees to perform essential functions so the workplace can operate even if key employees are absent.



Personal Protective Equipment (PPE)

**Require the appropriate type of PPE for employees and customers.
Consider the following:**

- Provide cloth face coverings and/or face shields to employees. Consider distributing gloves to employees, if needed.
- Provide hand sanitizer and disinfectant wipes throughout multiple locations within the building (e.g. meeting areas, reception areas, and common spaces).

Public Health Guidance for REAL ESTATE



Conduct Risk Assessment

Establish critical protective guidelines. Consider the following questions:

- Are there locations where employees routinely congregate?
- Are tools and equipment frequently shared by multiple employees?
- Does customer flow allow for social distancing measures?
- Where are areas in your business that would not allow customers and staff to properly distance?
- Who are your high risk employees?
- Is your business actively engaged in activities that promote disease transmission?
- Does your business have existing cleaning and disinfecting procedures?
- How quickly can you communicate with employees?
- Are communication resources needed in multiple languages?



Physical Distancing

Establish policies and procedures for social distancing. Consider the following:

- Maintain 6-foot separation between employees, and discourage shared spaces.
- Avoid meetings or groups of more than 10 employees, clients, or customers; limit the number of on-site customers to continuously maintain 6-foot distancing.
- Open houses or showings should include social distancing measures while wearing appropriate face coverings; utilize virtual tours as much as possible.



Engineering & Environmental Controls

Improve engineering controls and perform routine environmental cleaning.

Consider the following:

- Ensure that ventilation systems operate properly and increase circulation of outdoor air as much as possible.
- Support respiratory etiquette and hand hygiene for employees, customers, and visitors:
 - Provide tissues, no-touch disposal receptacles, and soap and water at each showing (if not readily available, use alcohol-based hand sanitizer that is at least 60% alcohol). Ensure adequate supplies are maintained and place hand sanitizers in multiple locations.
 - Place posters that encourage hand hygiene to help stop the spread of COVID-19 at the entrance to your showing and in other areas where they are likely to be seen.
 - Discourage handshaking – encourage the use of other non-contact methods of greeting.
- Consider installing plastic shields to provide protection between employees and customers.
- Use contactless payment and paperwork solutions when possible.
- Perform routine environmental cleaning and disinfection
 - Routinely disinfect all frequently touched surfaces. For disinfection, most common EPA-registered household disinfectants should be effective. Follow the manufacturer's instructions for all cleaning and disinfection products.
 - For disinfection, most common EPA-registered household disinfectants should be effective. Follow the manufacturer's instructions for all cleaning and disinfection products.

Public Health Guidance for REAL ESTATE

(continued)



Administrative Controls (continued)

**Establish administrative controls while employees and visitors are onsite.
Consider the following:**

- Implement symptom monitoring protocols such as temperature and symptom checks.
- Require employees with symptoms to stay home or telework.
- Accommodate employees who are vulnerable individuals; create special hours when practical.
- Provide flexible options for employees with child or elder-care obligations.
- Complete required paperwork through electronic measures, utilizing tele- or conference call meetings for finalizing paperwork.



Personal Protective Equipment (PPE)

**Require the appropriate type of PPE for employees and customers.
Consider the following:**

- Provide appropriate PPE, such as cloth face coverings and gloves, as needed.

Public Health Guidance for **GOVERNMENT**



Conduct Risk Assessment

Establish critical protective guidelines. Consider the following questions:

- Are there locations where employees routinely congregate?
- Are tools and equipment frequently shared by multiple employees?
- Does customer flow allow for social distancing measures?
- Where are areas in your business that would not allow customers and staff to properly distance?
- Who are your high risk employees?
- Is your business actively engaged in activities that promote disease transmission?
- Does your business have existing cleaning and disinfecting procedures?
- How quickly can you communicate with employees?
- Are communication resources needed in multiple languages?

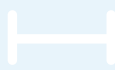

Physical Distancing

Establish policies and procedures for social distancing. Consider the following:

- Implement flexible worksites (e.g., telework), work hours (staggered shifts), and meeting and travel options (e.g. use video-/tele-conferencing for meetings, postpone non-essential meetings or events; travel separately).
- When video-/tele-conferencing is not possible, hold meetings in open, well-ventilated spaces.
- Increase physical space between employees at the worksite, and between employees and customers – especially in work spaces, breakroom/cafeteria, and waiting rooms (e.g., drive through options, partitions). Install plastic shields between reception staff and visitors.
- Establish policies and procedures for social distancing.
- Downsize service operations, offering services remotely (phone, web, video) and the delivery of services through curbside pickup.
- Limit the number of people in elevators, bathroom, meeting spaces, and other common spaces; consider redesign office spaces and environment.
- Consider canceling, adjusting, or postponing large work-related meetings or gathering that can only occur in-person.



Engineering & Environmental Controls

Improve engineering controls and perform routine environmental cleaning.

Consider the following:

- Increase ventilation rates and percentage of outdoor air that circulates into the system.
- Support respiratory etiquette and hand hygiene for employees, customers, and visitors by:
 - Provide tissues and no-touch disposal receptacles, and soap and water in the workplace (if not readily available, use alcohol-based hand sanitizer that is at least 60% alcohol). Ensure adequate supplies are maintained and place hand sanitizers in multiple locations.
 - Place posters that encourage hand hygiene to help stop the spread at the entrance to your workplace and in other areas where they are likely to be seen.
 - Discourage handshaking – encourage the use of other non-contact methods of greeting.
 - Direct employees to visit CDC website for information on coughing and sneezing etiquette and handwashing.

Public Health Guidance for **GOVERNMENT**

(continued)



Engineering & Environmental Controls (continued)

Improve engineering controls and perform routine environmental cleaning. Consider the following:

- Perform routine environmental cleaning and disinfection.
 - Routinely disinfect all frequently touched surfaces in the workplace, such as workstations, keyboards, telephones, handrails, and doorknobs.
 - For disinfection, most common EPA-registered household disinfectants should be effective. Follow the manufacturer's instructions for all cleaning and disinfection products.
- Discourage workers from using co-workers' phones, desks, offices, or other office tools and equipment, when possible. If they must use, provide disposable wipes so that commonly used surfaces (including doorknobs, remote controls, etc.) can be wiped down by between each use.
- Perform enhanced cleaning and disinfection after suspected cases of COVID-19 have been in the facility.



Administrative Controls

Establish administrative controls while employees and visitors are onsite. Consider the following:

- Identify a workplace coordinator who will be responsible for COVID-19 issues and their impact at the workplace.
 - Implement daily health and temperature screenings for employees upon arriving to work.
 - Implement similar health screening for visitors and clients entering building.
 - Provide education and training on new processes, COVID-19, and the use of PPE while in the building.
- Review Human Resource policies to make sure that policies and practices are consistent with both public health recommendations and existing state and federal workplace laws.
 - Implement flexible sick leave and supportive policies and practices.
 - Ensure that sick leave policies are flexible and consistent with public health guidance and provide employee training on new policies. If sick leave is not a benefit, it is recommended that the employer draft a non-punitive emergency sick leave policy.
 - Maintain flexible policies that permit employees to stay home to care for a sick family member or take care of children due to school/daycare closures.
 - Employers should not require a positive COVID-19 test result or a healthcare provider's note for employees who are sick to validate their illness, qualify for sick leave, or to return to work.
 - Connect employees to Employee Assistance Program (EAP) resources and community resources as needed. Employees may need additional social, behavioral, and other services for mental health support.
 - Develop communication plans for employee concerns and stresses.
- Assess essential functions and the reliance that the community has on your services/products.
 - Identify alternate supply chains for critical goods and services as some may be in higher demand or unavailable.
 - Talk with companies that provide your organization with contract or temporary employees about the importance of sick employees staying home and encourage them to develop non-punitive leave policies.

Public Health Guidance for **GOVERNMENT**

(continued)



Administrative Controls (continued)

**Establish administrative controls while employees and visitors are onsite.
Consider the following:**

- Assess essential functions and the reliance that the community has on your services/products (continued).
 - Determine how you will operate if absenteeism spikes from increases in sick employees, those who stay home to care for sick family members, and those who must stay home to watch their children. Plan to monitor and respond to absenteeism in the workplace. Implement plans to continue your essential business functions. Prepare to institute flexible workplace and leave policies. Cross-train employees to perform essential functions so the workplace can operate even if key employees are absent.



Personal Protective Equipment (PPE)

**Require the appropriate type of PPE for employees and customers.
Consider the following:**

- Require staff to wear cloth face coverings.
- Provide cloth face coverings and/or face shields to employees. Consider distributing gloves to employees, if needed.
- PPE usage will vary due to job requirements and work environments. Additional PPE may include medical or surgical gowns, fluid-resistant coveralls, aprons, other disposable/reusable protective clothing, goggles, face shields, gloves and/or cloth masks.
- Provide visitors and clients a face covering as an option upon entering the building.
- Provide hand sanitizer and disinfectant wipes throughout multiple locations within the building (e.g. meeting areas, reception areas, and common spaces).

Public Health Guidance for **MANUFACTURING**



Conduct Risk Assessment

Establish critical protective guidelines. Consider the following questions:

- Are there locations where employees routinely congregate?
- Are tools and equipment frequently shared by multiple employees?
- Does customer flow allow for social distancing measures?
- Where are areas in your business that would not allow customers and staff to properly distance?
- Who are your high risk employees?
- Is your business actively engaged in activities that promote disease transmission?
- Does your business have existing cleaning and disinfecting procedures?
- How quickly can you communicate with employees?
- Are communication resources needed in multiple languages?

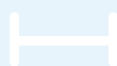

Physical Distancing

Establish policies and procedures for social distancing. Consider the following:

- Develop social distancing plan. Configure work spaces at least six feet apart. Mark appropriate distances for lines, in locker rooms, breakrooms, and other necessary locations so staff have visual cues to maintain distance.
- Implement flexible worksites (e.g., telework), work hours (staggered shifts), and meeting and travel options (e.g. use video-/tele-conferencing for meetings, postpone non-essential meetings or events; travel separately).
- Establish staggered start, break, and lunch times to reduce density during entry and screening stations.
- When video-/tele-conferencing is not possible, hold meetings in open, well-ventilated spaces where distancing is possible.
- Consider canceling, adjusting, or postponing large work-related meetings or gathering that can only occur in-person.
- Increase physical space between employees at the worksite, and between employees and customers – especially in work spaces, breakroom/cafeteria, and waiting rooms. Install plastic shields between reception staff and visitors.
- Downsize service operations, offering services remotely (phone, web, video) and the delivery of services through curbside pickup.
- Limit the number of people in elevators, bathroom, meeting spaces, and other common spaces; consider reconfiguring office spaces and environment.



Engineering & Environmental Controls

Improve engineering controls and perform routine environmental cleaning.

Consider the following:

- Consider shields between work lines.
- Increase ventilation rates and percentage of outdoor air that circulates into the system.

Public Health Guidance for **MANUFACTURING**

(continued)



Engineering & Environmental Controls (continued)

Improve engineering controls and perform routine environmental cleaning.

Consider the following:

- Support respiratory etiquette and hand hygiene for employees, customers, and visitors:
 - Provide tissues, no-touch disposal receptacles, and soap and water in the workplace (if not readily available, use alcohol-based hand sanitizer that is at least 60% alcohol). Employees should wash their hands frequently throughout the day. If hands are visibly dirty, soap and water should be chosen over hand sanitizer. Ensure adequate supplies are maintained and place hand sanitizers in multiple locations.
 - Place posters that encourage hand hygiene to help stop the spread of COVID-19 at the entrance to your workplace and in other areas where they are likely to be seen.
 - Discourage handshaking – encourage the use of other non-contact methods of greeting.
 - Direct employees to visit CDC website for information on coughing and sneezing etiquette and handwashing.
- Discourage workers from using co-workers' phones, desks, offices, or other office tools and equipment, when possible. If they must use, provide disposable wipes so that commonly used surfaces (including doorknobs, remote controls, etc.) can be wiped down by between each use.



Administrative Controls

Establish administrative controls while employees and visitors are onsite.

Consider the following:

- Identify a workplace coordinator who will be responsible for COVID-19 issues and their impact at the workplace.
 - Implement daily health and temperature screenings for employees upon arriving to work.
 - Provide education and training on new processes, COVID-19, and the use of PPE while in the workplace.
- Review Human Resource policies to make sure that policies and practices are consistent with both public health recommendations and existing state and federal workplace laws.
 - Implement flexible sick leave and supportive policies and practices.
 - Ensure that sick leave policies are flexible and consistent with public health guidance and provide employee training on new policies. If sick leave is not a benefit, it is recommended that the employer draft a non-punitive emergency sick leave policy.
 - Maintain flexible policies that permit employees to stay home to care for a sick family member or take care of children due to school/daycare closures.
 - Employers should not require a positive COVID-19 test result or a healthcare provider's note for employees who are sick to validate their illness, qualify for sick leave, or to return to work.
 - Connect employees to Employee Assistance Program (EAP) resources and community resources as needed. Employees may need additional social, behavioral, and other services for mental health support.
- Assess essential functions and the reliance that the community has on your services/products.
 - Be prepared to change your business practices, if needed, to maintain critical operations (e.g., identify alternative suppliers, prioritize existing customers, or temporarily suspend some of your operations if needed).

Public Health Guidance for **MANUFACTURING**

(continued)



Administrative Controls (continued)

Establish administrative controls while employees and visitors are onsite.

Consider the following:

- Assess essential functions and the reliance that the community has on your services/products (continued).
 - Identify alternate supply chains for critical goods and services as some may be in higher demand or unavailable.
 - Talk with companies that provide your business with contract or temporary employees about the importance of sick employees staying home and encourage them to develop a non-punitive leave policies.
 - Talk with business partners about response plans. Share best practices with other businesses in your communities (especially in your supply chain), Chambers of Commerce, and associations to improve community response efforts.
 - Determine how you will operate if absenteeism spikes from increases in sick employees, those who stay home to care for sick family members, and those who must stay home to watch their children. Plan to monitor and respond to absenteeism in the workplace. Implement plans to continue your essential business functions. Prepare to institute flexible workplace and leave policies. Cross-train employees to perform essential functions so the workplace can operate even if key employees are absent.



Personal Protective Equipment (PPE)

Require the appropriate type of PPE for employees and customers.

Consider the following:

- Require all employees to wear cloth face coverings and gloves.
- Those workers with medium exposure risk (as defined in the Risk Assessment section on pages 10-11) need to wear some combination of gloves, face coverings and/or face shield or goggles. Instruction on proper donning and doffing (placing on and taking off) of PPE should be provided.

Public Health Guidance for CONSTRUCTION



Conduct Risk Assessment

Establish critical protective guidelines. Consider the following questions:

- Are there locations where employees routinely congregate?
- Are tools and equipment frequently shared by multiple employees?
- Does customer flow allow for social distancing measures?
- Where are areas in your business that would not allow customers and staff to properly distance?
- Who are your high risk employees?
- Is your business actively engaged in activities that promote disease transmission?
- Does your business have existing cleaning and disinfecting procedures?
- How quickly can you communicate with employees?
- Are communication resources needed in multiple languages?

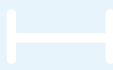

Physical Distancing

Establish policies and procedures for social distancing. Consider the following:

- Practice sensible social distancing and maintain six feet between co-workers, where possible.
- Advise workers to avoid physical contact with others and direct employees/contractors/visitors to increase personal space to at least six feet, where possible.
- Where work trailers are used, all workers should maintain social distancing while inside the trailers.
- Keep in-person meetings (including toolbox talks and safety meetings) as short as possible, limit the number of workers in attendance, and use social distancing practices.
- Establish flexible work hours (e.g., staggered shifts), if feasible.



Engineering & Environmental Controls

Improve engineering controls and perform routine environmental cleaning.

Consider the following:

- Support respiratory etiquette and hand hygiene for employees, customers, and visitors:
 - Provide tissues, no-touch disposal receptacles, and soap and water at the worksite (if not readily available, use alcohol-based hand sanitizer that is at least 60% alcohol). Employees should wash their hands frequently throughout the day. If hands are visibly dirty, soap and water should be chosen over hand sanitizer. Ensure adequate supplies are maintained and place hand sanitizers in multiple locations.
 - Place posters that encourage hand hygiene to help stop the spread of COVID-19 at the entrance to your workplace and in other areas where they are likely to be seen.
 - Discourage handshaking – encourage the use of other non-contact methods of greeting.
 - Direct employees to visit CDC website for information on coughing and sneezing etiquette and handwashing.
- To the extent tools or equipment must be shared, provide and instruct workers in the use of alcohol-based wipes to clean tools before and after use. When cleaning tools and equipment, workers should consult manufacturer recommendations for proper cleaning techniques and restrictions.

Public Health Guidance for CONSTRUCTION

(continued)



Engineering & Environmental Controls (continued)

Improve engineering controls and perform routine environmental cleaning.

Consider the following:

- For work activities where social distancing is a challenge, consider limiting the duration of these activities and/or implementing innovative approaches, such as temporarily moving or repositioning workstations to create more distance or installing barriers (e.g., Plexiglas shields) between workstations.
- Clean and disinfect portable jobsite toilets regularly. Hand sanitizer dispensers should be filled regularly. Frequently touched items (i.e., door pulls and toilet seats) should be disinfected.



Administrative Controls

Establish administrative controls while employees and visitors are onsite.

Consider the following:

- Identify a workplace coordinator who will be responsible for COVID-19 issues and their impact at the workplace.
 - Implement daily health and temperature screenings for employees upon arriving to work.
 - Provide education and training on new processes, COVID-19, and the use of PPE while in the building.
- Review Human Resource policies to make sure that policies and practices are consistent with both public health recommendations and existing state and federal workplace laws.
 - Implement flexible sick leave and supportive policies and practices.
 - Ensure that sick leave policies are flexible and consistent with public health guidance and provide employee training on new policies. If sick leave is not a benefit, it is recommended that the employer draft a non-punitive emergency sick leave policy.
 - Maintain flexible policies that permit employees to stay home to care for a sick family member or take care of children due to school/daycare closures.
 - Employers should not require a positive COVID-19 test result or a healthcare provider's note for employees who are sick to validate their illness, qualify for sick leave, or to return to work.
 - Connect employees to Employee Assistance Program (EAP) resources and community resources as needed. Employees may need additional social, behavioral, and other services for mental health support.
- Assess essential functions and the reliance that the community has on your services/products.
 - Be prepared to change your business practices, if needed, to maintain critical operations (e.g., identify alternative suppliers, prioritize existing customers, or temporarily suspend some of your operations if needed).
 - Identify alternate supply chains for critical goods and services as some may be in higher demand or unavailable.
 - Talk with companies that provide your business with contract or temporary employees about the importance of sick employees staying home and encourage them to develop non-punitive leave policies.
 - Talk with business partners about response plans. Share best practices with other businesses in your communities (especially in your supply chain), Chambers of Commerce, and associations to improve community response efforts.

Public Health Guidance for CONSTRUCTION

(continued)



Administrative Controls (continued)

**Establish administrative controls while employees and visitors are onsite.
Consider the following:**

- Encourage workers to report any safety and health concerns.
- Train workers how to properly put on, use/wear and take off protective clothing and equipment.



Personal Protective Equipment (PPE)

**Require the appropriate type of PPE for employees and customers.
Consider the following:**

- Allow workers to wear face coverings over their nose and mouth to prevent spreading COVID-19.
- Continue to use other normal control measures, including personal protective equipment (PPE), necessary to protect workers from other job hazards associated with construction activities.

Public Health Guidance for RESTAURANTS



Conduct Risk Assessment

Establish critical protective guidelines. Consider the following questions:

- Are there locations where employees routinely congregate?
- Are tools and equipment frequently shared by multiple employees?
- Does customer flow allow for social distancing measures?
- Where are areas in your business that would not allow customers and staff to properly distance?
- Who are your high risk employees?
- Is your business actively engaged in activities that promote disease transmission?
- Does your business have existing cleaning and disinfecting procedures?
- How quickly can you communicate with employees?
- Are communication resources needed in multiple languages?

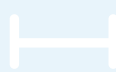

Physical Distancing

Establish policies and procedures for social distancing. Consider the following:

- Provide take-out and curbside pick-up.
- Increase remote ordering capacity and infrastructure support through phone and online ordering.
- Conduct an evaluation of your facility to identify and apply operational changes in order to maintain social distancing if offering take-out/carry-out options.
- Establish designated pick-up zones for customers to help maintain social distancing.
- Practice social distancing when delivering food (e.g., offering 'no touch' deliveries and sending text alerts/calling when deliveries have arrived).
- Remind customers to stand at least six feet apart while waiting to order or for pick-up.
- Consider strategies to minimize face-to-face contact (e.g., drive-thru windows, phone-based communication, telework).
- If restaurant is open for sit-down dining all tables should be six feet apart, and tables should not seat more than six people. Outdoor eating and drinking with six feet distancing is permitted.
- Reduce on premise capacity by 50% and limit to maximum of 50 people, not including staff.



Engineering & Environmental Controls

Improve engineering controls and perform routine environmental cleaning.

Consider the following:

- Increase ventilation rates; increase percentage of outdoor air that circulates into system.
- Stop self-serve style operations, including salad bars, buffets, and dispensers.
- Install physical barriers, such as clear plastic guards, where feasible.
- Establish online, no-touch payment systems/processes.
- Eliminate paper menus.
- Eliminate all table condiments.

Public Health Guidance for RESTAURANTS

(continued)



Administrative Controls

**Establish administrative controls while employees and visitors are onsite.
Consider the following:**

- Screen employees daily for symptoms (fever, cough, shortness of breath).
- Employees who have symptoms should notify their supervisor and stay home.
- Sick employees should follow CDC recommended steps. Employees should not return to work until the criteria to discontinue home isolation is met, in consultation with healthcare providers and state and local health departments.
- Employees who are well but who have a sick family member at home with COVID-19 should notify their supervisor and follow CDC guidelines.
- Allow high risk employees (people over 60, pregnant women, people with underlying health conditions) to stay home or temporarily assign lower-risk duties.
- While this isn't possible for most restaurant employees, evaluate and establish policies and tools that will allow employees with administrative or financial work responsibilities to work from home. Be sure to consider the hardware and technology needs.
- Promote hand and respiratory hygiene.
- Ensure sufficient availability of alcohol-based hand sanitizers.
- Place posters that encourage hand hygiene to help stop the spread of COVID-19 at the entrance to your workplace and in other areas where they are likely to be seen.
- Continue to regularly clean and sanitize any objects or surfaces, with special attention to high-touch surfaces.
- Follow safe food handling requirements, including handwashing with warm, soapy water for at least 20 seconds.



Personal Protective Equipment (PPE)

**Require the appropriate type of PPE for employees and customers.
Consider the following:**

- Workers with medium exposure risk (as defined in the Risk Assessment section on pages 10-11) need to wear some combination of gloves, cloth mask, and/or face shield or goggles.
- Require all employees to wear face coverings and gloves. Consider providing cloth face coverings.
- Provide handwashing and sanitizing stations for employees and customers.
- Consider requiring customers to wear cloth face coverings upon entry. Keep in mind some customers may not be able to wear face coverings due to medical conditions. For this reason, be mindful of discriminatory behavior from staff or customers.

Public Health Guidance for BARS



Conduct Risk Assessment

Establish critical protective guidelines. Consider the following questions:

- Are there locations where employees routinely congregate?
- Are tools and equipment frequently shared by multiple employees?
- Does customer flow allow for social distancing measures?
- Where are areas in your business that would not allow customers and staff to properly distance?
- Who are your high risk employees?
- Is your business actively engaged in activities that promote disease transmission?
- Does your business have existing cleaning and disinfecting procedures?
- How quickly can you communicate with employees?
- Are communication resources needed in multiple languages?



Physical Distancing

Establish policies and procedures for social distancing. Consider the following:

- Limit service to drive-thru, or curbside pickup options only.
- Provide physical guides, such as tape on floors or sidewalks to ensure customers remain at least six feet apart in lines or ask customers to wait in their vehicles or away from the establishment while waiting to pick up food.
- Post signs to inform customers of food pickup protocols.
- Restrict the number of employees in shared spaces including kitchen, break room, and offices.
- Rotate or stagger shifts to limit the number of employees in the workplace at the same time; adjust operating hours.
- As reopen continues, reduce occupancy and limit the size of parties dining together to sizes that ensure that all customer parties remain at least six feet apart.



Engineering & Environmental Controls

Improve engineering controls and perform routine environmental cleaning.

Consider the following:

- Support respiratory etiquette and hand hygiene for employees, customers, and visitors by:
 - Provide tissues, no-touch disposal receptacles, and soap and water (if not readily available, use alcohol-based hand sanitizer that is at least 60% alcohol). Ensure adequate supplies are maintained and place in multiple locations.
 - Place posters that encourage hand hygiene to help stop the spread COVID-19 in areas where they are likely to be seen.
 - Discourage handshaking between employees – encourage the use of other non-contact methods of greeting.
 - Direct employees to visit CDC website for information on coughing and sneezing etiquette and handwashing.
- Perform routine environmental cleaning and disinfection.
 - Routinely disinfect all frequently touched surfaces
 - For disinfection, most common EPA-registered household disinfectants should be effective. Follow the manufacturer's instructions for all cleaning and disinfection products.

Public Health Guidance for BARS

(continued)



Engineering & Environmental Controls (continued)

Improve engineering controls and perform routine environmental cleaning.

Consider the following:

- Use touchless payment and no-touch trash cans and doors as much as possible, when available. Ask customers and employees to exchange cash or credit cards by placing in a receipt tray or on the counter rather than by hand and wipe any pens, counters, or hard surfaces between each use or customer. If possible, use phone app technology to alert patrons when their table is ready to avoid touching and use of ‘buzzers’.
- Increase ventilation rates; increase percentage of outdoor air that circulates into system.
- Stop self-serve style operations including salad bars, buffets, and dispensers.
- Eliminate paper menus and all table condiments.
- Consider installing physical barriers, such as plastic guards and partitions at cash registers, or other food pickup areas where maintaining physical distance of six feet is difficult.
- All tables and bar stools should remain at least six feet apart, marking tables and stools that are not for use.



Administrative Controls

Establish administrative controls while employees and visitors are onsite.

Consider the following:

- Identify a workplace coordinator who will be responsible for COVID-19 issues and their impact at the workplace.
 - Implement daily health and temperature screenings for employees upon arriving to work.
 - Employees should know who the workplace coordinator is and how to contact them.
- Review Human Resource policies to make sure that policies and practices are consistent with both public health recommendations and existing state and federal workplace laws.
 - Implement flexible sick leave and supportive policies and practices.
 - Ensure that sick leave policies are flexible and consistent with public health guidance and provide employee training on new policies. If sick leave is not a benefit, employer might want to draft non-punitive emergency sick leave policy.
 - Maintain flexible policies that permit employees to stay home to care for a sick family member or take care of children due to school/daycare closures.
 - Employers should not require a positive COVID-19 test result or a healthcare provider’s note for employees who are sick to validate their illness, qualify for sick leave, or to return to work.
 - Connect employees to Employee Assistance Program (EAP) resources and community resources as needed. Employees may need additional social, behavioral, and other services for mental health support.
- Assess essential functions and the reliance that the community have on your services/products.
 - Identify alternate supply chains for critical goods and services as some may be in higher demand or unavailable.
 - Talk with companies that provide your business with contract or temporary employees about the importance of sick employees staying home and encourage them to develop non-punitive leave policies.

Public Health Guidance for BARS

(continued)



Administrative Controls (continued)

Establish administrative controls while employees and visitors are onsite. Consider the following:

- Assess essential functions and the reliance that the community has on your services/products (continued).
 - Talk with business partners about response plans. Share best practices with other businesses in your communities (especially in your supply chain), Chambers of Commerce, and associations to improve community response efforts.
 - Determine how you will operate if absenteeism spikes from increases in sick employees, those who stay home to care for sick family members, and those who must stay home to watch their children. Plan to monitor and respond to absenteeism in the workplace. Implement plans to continue your essential business functions. Prepare to institute flexible workplace and leave policies. Cross-train employees to perform essential functions so the workplace can operate even if key employees are absent.
- Allow high risk employees (people over 60, pregnant women, people with underlying health conditions) to stay home or temporarily assign to non-public contact duties.
- While this is not possible for most bar employees, evaluate and establish policies and tools that will allow employees with administrative or financial work responsibilities to do so from home. Be sure to consider the hardware needs.



Personal Protective Equipment (PPE)

Require the appropriate type of PPE for employees and customers. Consider the following:

- Workers with medium exposure risk (as defined in the Risk Assessment on pages 10-11) need to wear some combination of gloves, cloth face covering, and/or face shield or goggles.
- Require all employees to wear a cloth face covering and gloves. Consider providing cloth face coverings.
- Provide handwashing and hand sanitizing stations for employees and customers.
- Consider requiring customers to wear cloth face coverings upon entry. Keep in mind some customers may not be able to wear face coverings due to medical conditions. For this reason, be mindful of discriminatory behavior from staff or customers.

Public Health Guidance for **RETAIL ESTABLISHMENTS**



Conduct Risk Assessment

Establish critical protective guidelines. Consider the following questions:

- Are there locations where employees routinely congregate?
- Are tools and equipment frequently shared by multiple employees?
- Does customer flow allow for social distancing measures?
- Where are areas in your business that would not allow customers and staff to properly distance?
- Who are your high risk employees?
- Is your business actively engaged in activities that promote disease transmission?
- Does your business have existing cleaning and disinfecting procedures?
- How quickly can you communicate with employees?
- Are communication resources needed in multiple languages?

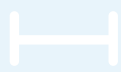

Physical Distancing

Establish policies and procedures for social distancing. Consider the following:

- Ensure that employees and customers limit close contact (stay six feet apart). Appoint a staff person who will ensure that people standing in any lines or meeting in rooms maintain physical distance.
- In areas of high-volume traffic, utilize spacing tools for social distancing screenings and lines (e.g., place tape on floor to keep people adequately spaced; place arrows in the aisle to direct the flow of movement in one direction).
- Provide services by appointment, take-out/delivery options or curbside pick-up. Establish designated pick-up zones for customers to help maintain social distancing.
- Establish online, no touch payment systems/processes.
- Consider strategies to minimize face-to-face contact and deliver services remotely (e.g., drive-thru windows, phone-based communication, online order).
- Reduce on premise capacity by 50% and limit to a maximum of 50 people, not including staff.
- Reconfigure retail space to enable social distancing (e.g. reduce inventory on floor, user smaller displays, strategically place inventory).
- Establish staggered lunch and break times for staff.



Engineering & Environmental Controls

Improve engineering controls and perform routine environmental cleaning. Consider the following:

- Consider installing physical barriers, such as clear plastic guards where feasible (e.g. purchase point).
- Increase ventilation rates and percentage of outdoor air that circulates into the system.
- Support respiratory etiquette and hand hygiene for employees, customers, and visitors by:
 - Provide tissues, no-touch disposal receptacles, and soap and water in the workplace (if not readily available, use alcohol-based hand sanitizer that is at least 60% alcohol). Employees should wash their hands frequently throughout the day. If hands are visibly dirty, soap and water should be chosen over hand sanitizer. Ensure adequate supplies are maintained and place hand sanitizers in multiple locations.
 - Place posters that encourage hand hygiene to help stop the spread of COVID-19 at the entrance to your workplace and in other areas where they are likely to be seen.

Public Health Guidance for **RETAIL ESTABLISHMENTS**

(continued)



Engineering & Environmental Controls (continued)

Improve engineering controls and perform routine environmental cleaning.

Consider the following:

- Support respiratory etiquette and hand hygiene for employees, customers, and visitors by: (continued).
 - Discourage handshaking – encourage the use of other non-contact methods of greeting.
 - Direct employees to visit CDC website for information on coughing and sneezing etiquette and handwashing.
- Discourage workers from using co-workers' phones, desks, offices, or other office tools and equipment, when possible. If they must use, provide disposable wipes so that commonly used surfaces (including doorknobs, remote controls, etc.) can be wiped down between each use.



Administrative Controls

Establish administrative controls while employees and visitors are onsite.

Consider the following:

- Identify a workplace coordinator who will be responsible for COVID-19 issues and their impact at the workplace.
 - Implement daily health and temperature screening for employees upon arriving to work.
 - Provide education and training on new processes, COVID-19, and the use of PPE while in the building.
- Review Human Resource policies to make sure that policies and practices are consistent with both public health recommendations and existing state and federal workplace laws.
 - Implement flexible sick leave and supportive policies and practices.
 - Ensure that sick leave policies are flexible and consistent with public health guidance and provide employee training on new policies. If sick leave is not a benefit, it is recommended that employers draft a non-punitive emergency sick leave policy.
 - Maintain flexible policies that permit employees to stay home to care for a sick family member or take care of children due to school/daycare closures.
 - Employers should not require a positive COVID-19 test result or a healthcare provider's note for employees who are sick to validate their illness, qualify for sick leave, or to return to work.
 - Connect employees to Employee Assistance Program (EAP) resources and community resources as needed. Employees may need additional social, behavioral, and other services for mental health support.
 - Consider temporarily assigning employees at high risk for virus to duties that do not involve close contact with the public.
- Assess essential functions and the reliance that the community has on your services/products.
 - Talk with companies that provide your business with contract or temporary employees about the importance of sick employees staying home and encourage them to develop non-punitive leave policies.
 - Talk with business partners about response plans. Share best practices with other businesses in your communities (especially in your supply chain), Chambers of Commerce, and associations to improve community response efforts.

Public Health Guidance for **RETAIL ESTABLISHMENTS**

(continued)



Administrative Controls (continued)

**Establish administrative controls while employees and visitors are onsite.
Consider the following:**

- Assess essential functions and the reliance that the community has on your services/products (continued).
 - Determine how you will operate if absenteeism spikes from increases in sick employees, those who stay home to care for sick family members, and those who must stay home to watch their children. Plan to monitor and respond to absenteeism in the workplace. Implement plans to continue your essential business functions. Cross-train employees to perform essential functions so the workplace can operate even if key employees are absent.



Personal Protective Equipment (PPE)

**Require the appropriate type of PPE for employees and customers.
Consider the following:**

- Workers with medium exposure risk (as defined in the Risk Assessment section on pages 10-11) need to wear some combination of gloves, face coverings, and/or face shield or goggles.
- Consider providing cloth face coverings.
- Consider requiring customers to wear cloth face coverings upon entry. Keep in mind some customers may not be able to wear face coverings due to medical conditions. For this reason, be mindful of discriminatory behavior from staff or customers.

Public Health Guidance for **PERSONAL SERVICES**

Salons | Barbershops | Tattoo Parlors | Spas



Conduct Risk Assessment

Establish critical protective guidelines. Consider the following questions:

- Are there locations where employees routinely congregate?
- Are tools and equipment frequently shared by multiple employees?
- Does customer flow allow for social distancing measures?
- Where are areas in your business that would not allow customers and staff to properly distance?
- Who are your high risk employees?
- Is your business actively engaged in activities that promote disease transmission?
- Does your business have existing cleaning and disinfecting procedures?
- How quickly can you communicate with employees?
- Are communication resources needed in multiple languages?



Physical Distancing

Establish policies and procedures for social distancing. Consider the following:

- Staff work spaces must be assessed and reconfigured so staff in the building can socially distance and limit working together in confined areas.
- Spread out appointments between all patrons so there is no waiting or limited number of people in waiting areas. Waiting areas should be reconfigured to accommodate at least six feet between patrons.



Engineering & Environmental Controls

Improve engineering controls and perform routine environmental cleaning. Consider the following:

- Increase ventilation rates and percentage of outdoor air that circulates into the system.
- Support respiratory etiquette and hand hygiene for employees, customers, and visitors by:
 - Provide tissues, no-touch disposal receptacles, and soap and water in the workplace (if not readily available, use alcohol-based hand sanitizer that is at least 60% alcohol). Ensure adequate supplies are maintained and place hand sanitizers in multiple locations.
 - Place posters that encourage hand hygiene to help stop the spread of COVID-19 at the entrance to your workplace and in other areas where they are likely to be seen.
 - Discourage handshaking or hugging – encourage the use of other non-contact methods of greeting.
 - Direct employees to visit CDC website for information on coughing and sneezing etiquette and handwashing.
- Perform routine environmental cleaning and disinfection.
 - Routinely disinfect all frequently touched surfaces in the workplace, such as tools, implements, countertops, treatment rooms, chairs, hair washing stations, reception areas, styling stations, pedicure bowls, and restrooms. Wipe down workstations between all patrons. Provide disposable wipes to employees for ease of disinfecting areas.

Public Health Guidance for **PERSONAL SERVICES**

(continued)



Engineering & Environmental Controls (continued)

Improve engineering controls and perform routine environmental cleaning.

Consider the following:

- Perform routine environmental cleaning and disinfection.
 - For disinfection, most common EPA-registered household disinfectants should be effective. Follow the manufacturer's instructions for all cleaning and disinfection products.
 - Eliminate all magazines, book, newspapers, menus or other unnecessary papers or unnecessary objects that patrons frequently touch.
 - Avoid the use of cash, when possible. Credit/debit transactions preferred, using card swiping or chip insertion with no signature. Wipe credit/debit transaction pad between uses of each patron.
- Perform enhanced cleaning and disinfection after suspected cases of COVID-19 have been in the facility.



Administrative Controls

Establish administrative controls while employees and visitors are onsite.

Consider the following:

- Identify a workplace coordinator who will be responsible for COVID-19 issues and their impact at the workplace
 - Implement daily health and temperature screening for employees upon arriving to work.
- Review Human Resource policies to make sure that policies and practices are consistent with both public health recommendations and existing state and federal workplace laws.
 - Implement flexible sick leave and supportive policies and practices.
 - Ensure that sick leave policies are flexible and consistent with public health guidance and provide employee training on new policies. If sick leave is not a benefit, it is recommended that the employer draft a non-punitive emergency sick leave policy.
 - Maintain flexible policies that permit employees to stay home to care for a sick family member or take care of children due to school/daycare closures.
 - Employers should not require a positive COVID-19 test result or a healthcare provider's note for employees who are sick to validate their illness, qualify for sick leave, or to return to work.
 - Connect employees to Employee Assistance Program (EAP) resources and community resources as needed. Employees may need additional social, behavioral, and other services for mental health support.
- Assess essential functions and the reliance that the community has on your services/products.
 - Be prepared to change your business practices, if needed, to maintain critical operations (e.g., identify alternative suppliers, prioritize existing customers, or temporarily suspend some of your operations if needed).
 - Identify alternate supply chains for critical goods and services as some may be in higher demand or unavailable.
 - Talk with companies that provide your business with contract or temporary employees about the importance of sick employees staying home and encourage them to develop non-punitive leave policies.

Public Health Guidance for **PERSONAL SERVICES**

(continued)



Administrative Controls (continued)

**Establish administrative controls while employees and visitors are onsite.
Consider the following:**

- Assess essential functions and the reliance that the community have on your services/products.
 - Talk with business partners about response plans. Share best practices with other businesses in your communities (especially in your supply chain), Chambers of Commerce, and associations to improve community response efforts.
 - Determine how you will operate if absenteeism spikes from increases in sick employees, those who stay home to care for sick family members, and those who must stay home to watch their children. Plan to monitor and respond to absenteeism at the workplace. Implement plans to continue your essential business functions. Prepare to institute flexible workplace and leave policies. Cross-train employees to perform essential functions so the workplace can operate even if key employees are absent.
- Do not accept sick patrons. Have them reschedule. Send policy reminders through text or phone.



Personal Protective Equipment (PPE)

**Require the appropriate type of PPE for employees and customers.
Consider the following:**

- Provide gloves, face shields and protective washable gowns for procedures that require touching of patrons faces or neck areas (such as massages or spa treatments).
- Provide cloth masks to all employees. Consider distributing face shields and gloves to employees, if needed
- Provide hand sanitizer and disinfectant wipes at multiple locations throughout the building (e.g. meeting areas, reception areas, and common spaces).
- Follow all OSHA applicable regulations.
- Follow CDC guidelines for cloth and surgical masks or fabric coverings.
- Consider requiring customers to wear cloth face coverings upon entry. Keep in mind some customers may not be able to wear face coverings due to medical conditions. For this reason, be mindful of discriminatory behavior from staff or customers.

Public Health Guidance for **OUTDOOR ACTIVITY**

Recreation | Industry | Tourism



Conduct Risk Assessment

Establish critical protective guidelines. Consider the following questions:

- Are there locations where employees routinely congregate?
- Are tools and equipment frequently shared by multiple employees?
- Does customer flow allow for social distancing measures?
- Where are areas in your business that would not allow customers and staff to properly distance?
- Who are your high risk employees?
- Is your business actively engaged in activities that promote disease transmission?
- Does your business have existing cleaning and disinfecting procedures?
- How quickly can you communicate with employees?
- Are communication resources needed in multiple languages?



Physical Distancing

Establish policies and procedures for social distancing. Consider the following:

- Recreation
 - Maximize physical distance from others.
 - Limit group sizes.
 - Places where appropriate physical distancing may not be practical should be avoided unless precautionary measures are taken.
 - Avoid congregating in the parking lot or restrooms.
- Industry
 - Limit work crew sizes.
 - Travel separately to and from the job site.
 - Maximize physical distance between co-workers.
 - Maximize distance between staff and customers.
- Tourism
 - Limit group sizes.
 - Maximize physical distancing.
 - Consider tourism limitation by geographic region.
 - Places, events, services, and attractions where appropriate physical distancing may not be practical should be avoided unless precautionary measures are taken.
 - Avoid congregating in parking lot or restrooms.



Engineering & Environmental Controls

Improve engineering controls and perform routine environmental cleaning. Consider the following:

- Recreation
 - Close areas where physical distancing is not practical.
 - Employ barriers and signage to prevent access to closed buildings and playgrounds.
 - Use signage to limit occupancy and maximize physical distancing.
 - Eliminate trash receptacles with lids that require touching. Replace with no-touch trash receptacles. Require carry in/carry out.
 - Close courts for sports where physical contact is likely.
 - Pools remain closed.
 - Enhanced cleaning and sanitizing of common contact surfaces.

Public Health Guidance for **OUTDOOR ACTIVITY**

(continued)



Engineering & Environmental Controls (continued)

**Improve engineering controls and perform routine environmental cleaning.
Consider the following:**

- Industry
 - Signage and barriers to restrict vehicle occupancy.
 - Close common areas where employees congregate such as breakrooms.
 - Eliminate coffee pots and other shared non-essential items.
 - Enhanced cleaning and sanitizing of equipment and common contact surfaces.
- Tourism
 - Close buildings, services, attractions, and events where physical distancing is not practical.
 - Barriers and signage to prevent access to closed buildings.
 - Close common areas of buildings where physical distancing is not possible.
 - Barriers and signage to maximize physical distancing.
 - Enhanced cleaning and sanitizing of common contact surfaces.
 - Install physical barriers such as plexiglass between customer service staff and customers.
 - Adjust work areas to maximize separation between employees.
 - Install physical barriers such as plexiglass between employees when necessary.



Administrative Controls

**Establish administrative controls while employees and visitors are onsite.
Consider the following:**

- Recreation
 - Conduct health screenings with employees before starting work and at the end of shift.
 - Require currently or recently sick staff to stay at home.
 - Provide sick leave.
 - Utilize online payments for park permits, marina fees, and green fees.
 - Individual closures may be necessary if social distancing guidelines are not followed.
 - Enforcement by law enforcement agencies.
- Industry
 - Conduct health screenings with employees before starting work and at the end of shift.
 - Require currently or recently sick staff to stay at home.
 - Provide sick leave.
 - Provide electronic/online pay option for customers.
 - Provide supervision to ensure physical distancing is followed.
 - Minimize sharing of equipment.

Public Health Guidance for **OUTDOOR ACTIVITY**

(continued)



Administrative Controls (continued)

**Establish administrative controls while employees and visitors are onsite.
Consider the following:**

- Tourism
 - Limit number of customers.
 - Conduct health screenings with employees before starting work and at the end of shift.
 - Require currently or recently sick staff to stay at home.
 - Provide sick leave.
 - Provide electronic/online pre-pay only options for tickets to entrances.
 - Limit hours to allow for additional cleaning.
 - Health screening for guests, when practical.



Personal Protective Equipment (PPE)

**Require the appropriate type of PPE for employees and customers.
Consider the following:**

- Provide cloth face coverings and/or face shields to employees. Consider distributing gloves to employees, if needed.
- Provide hand sanitizer and disinfectant wipes throughout multiple locations within the building (e.g. meeting areas, reception areas, and common spaces).

Public Health Guidance for HEALTHCARE

Providers | EMS | Nursing Care Facilities



Conduct Risk Assessment

Establish critical protective guidelines. Consider the following questions:

- Are there locations where employees routinely congregate?
- Are tools and equipment frequently shared by multiple employees?
- Does customer flow allow for social distancing measures?
- Where are areas in your business that would not allow customers and staff to properly distance?
- Who are your high risk employees?
- Is your business actively engaged in activities that promote disease transmission?
- Does your business have existing cleaning and disinfecting procedures?
- How quickly can you communicate with employees?
- Are communication resources needed in multiple languages?



Physical Distancing

Establish policies and procedures for social distancing. Consider the following:

- Where appropriate, employers should develop policies and procedures for immediately isolating people who have signs and/or symptoms of COVID-19, and train workers to implement them. Move potentially infectious people to a location away from workers, customers, and other visitors. Although most worksites do not have specific isolation rooms, designated areas with closable doors may serve as isolation rooms until potentially sick people can be removed from the worksite.
- If possible, isolate people suspected of having COVID-19 separately from those with confirmed cases of the virus to prevent further transmission – particularly in worksites where medical screening, triage, or healthcare activities occur, using either permanent (e.g., wall/different room) or temporary barrier (e.g., plastic sheeting).
- Restrict the number of personnel entering isolation areas.



Engineering & Environmental Controls

Improve engineering controls and perform routine environmental cleaning.

Consider the following:

- Ensure appropriate air-handling system are installed and maintained in healthcare facilities www.cdc.gov/mmwr/preview/mmwrhtml/rr5210a1.htm.
- Recommend that patients with known or suspected COVID-19 (e.g., person under investigation) should be placed in an airborne infection isolation room (AIIR), if available.
- Use isolation rooms when available for performing aerosol-generating procedures on patients with known or suspected COVID-19. For postmortem activities, use autopsy suites or other similar isolation facilities when performing aerosol-generating procedures on the bodies of people who are known to have, or suspected of having, COVID-19 at the time of their death <https://www.cdc.gov/coronavirus/2019-ncov/hcp/guidance-postmortem-specimens.html>
- Use special precautions associated with Biosafety Level 3 when handling specimens from known or suspected COVID-19 patients.

Public Health Guidance for **HEALTHCARE**

(continued)



Administrative Controls

**Establish administrative controls while employees and visitors are onsite.
Consider the following:**

- Develop and implement policies that reduce exposure, such as grouping COVID-19 patients when single rooms are not available.
- Post signs requesting patients and family members to immediately report symptoms of respiratory illness on arrival at the healthcare facility and use disposable face masks.
- Consider offering enhanced medical monitoring of workers during COVID-19 outbreaks.
- Provide all workers with job-specific education and training on preventing transmission of COVID-19 including initial and routine training updates.
- Ensure that psychological and behavioral supports are available to address employee stress.



Personal Protective Equipment (PPE)

**Require the appropriate type of PPE for employees and customers.
Consider the following:**

- Most workers at high or very high exposure risk (as defined in the Risk Assessment section on page 10-11) likely need to wear gloves, a gown, a face shield/goggles, and either a face mask or respirator, depending on their job tasks and exposure risks.
- Those who work closely with (either in contact with, or within six feet of) patients know to be, or suspected of being infected with COVID-19, should wear respirators.
- PPE ensembles may vary, especially for workers in laboratories or morgue/mortuary facilities who may need additional protection against blood, body fluids, chemicals, and other materials to which they may be exposed. Additional PPE may include medical/surgical gowns, fluid-resistant coveralls, aprons, or other disposable or reusable protective clothing.
- Take steps to limit spread of the respiratory secretions of a person who may have COVID-19. Provide a face/surgical mask, if feasible and available, and ask the person to wear it, if tolerated. The face/surgical mask on the infected person acts to contain potentially infectious respiratory secretions at the source (e.g., the person's nose and mouth).
- Provide emergency responders and other essential personnel who may be exposed while outside of the facility with alcohol-based hand rubs containing at least 60% alcohol for decontamination in the field.

Public Health Guidance for **MASS GATHERING AREAS**

Libraries | Places of Worship | Community Centers



Conduct Risk Assessment

Establish critical protective guidelines. Consider the following questions:

- Are there locations where employees routinely congregate?
- Are tools and equipment frequently shared by multiple employees?
- Does customer flow allow for social distancing measures?
- Where are areas in your business that would not allow customers and staff to properly distance?
- Who are your high risk employees?
- Is your business actively engaged in activities that promote disease transmission?
- Does your business have existing cleaning and disinfecting procedures?
- How quickly can you communicate with employees?
- Are communication resources needed in multiple languages?

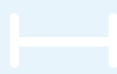

Physical Distancing

Establish policies and procedures for social distancing. Consider the following:

- Implement flexible worksites (e.g., telework), work hours (staggered shifts), and meeting and travel options (e.g. use video-/tele-conferencing for meetings, postpone non-essential meetings or events; travel separately).
- Staff should be included in facility risk assessments, especially in decision about how they do their own work.
- Facilities should participate in community conversation and coordinate with the local public health department to ensure their plans and procedures reflect the best practices adopted in the community.
- Deliver services remotely (e.g., phone, video, web) when possible.
- Deliver products through curbside pick-up or delivery when possible.
- Limit the number of people in elevators, bathroom, meeting spaces, and other common spaces; consider reconfiguring office spaces, large gathering spaces, and environment.
- Consider canceling, adjusting, or postponing large meetings or gathering that can only occur in-person.
- When video-/tele-conferencing is not possible, hold meetings in open, well-ventilated spaces where distancing is possible.
- Increase physical space – especially in waiting rooms, large gathering halls, and meeting rooms.
 - Libraries
 - Most employees who can do so should continue to work from home.
 - Libraries should continue to emphasize digital media and virtual experiences.
 - Limited access to physical objects like books and tools could be handled through a no-touch curbside service.
 - Staff work spaces must be assessed and reconfigured so staff in the building can socially distance.
 - Allowing access to actual library space will need to be implemented in phases as directed by social distancing requirement per Governor's orders.

Public Health Guidance for **MASS GATHERING AREAS**

(continued)

Physical Distancing (continued)

Establish policies and procedures for social distancing. Consider the following:

- Places of Worship
 - Allowing access to in-person services and gatherings will need to be implemented in phases as directed by social distancing requirements (group gathering requirements) per Governor's orders.
 - High risk populations should not attend in-person services during early re-entry phase. These populations can receive pastoral care from persons trained in COVID-19 safety.
- Community Centers
 - Allowing access to centers will need to be implemented in phases as directed by social distancing requirements (group gathering requirements) per Governor's orders.
 - Non-essential activities such as in-person classes and games should be cancelled; continue to expand virtual opportunities.
 - Essential activities, such as nutrition programs, can be offered in a safe manner in partnership with public health.
 - Once restrictions are lifted, prioritize essential programming and offer in small group settings.



Engineering & Environmental Controls

Improve engineering controls and perform routine environmental cleaning.

Consider the following:

- Increase ventilation rates and percentage of outdoor air that circulates into the system.
- Support respiratory etiquette and hand hygiene for employees and visitors:
 - Provide tissues, no-touch disposal receptacles, and soap and water in the center (if not readily available, use alcohol-based hand sanitizer that is at least 60% alcohol). Ensure adequate supplies are maintained and place hand sanitizers in multiple locations.
 - Place posters that encourage hand hygiene to help stop the spread of COVID-19 at the entrance of your building and in other areas where they are likely to be seen.
 - Discourage handshaking – encourage the use of other non-contact methods of greeting.
 - Direct employees to visit CDC website for information on coughing and sneezing etiquette and handwashing.
- Perform routine environmental cleaning and disinfection.
 - Routinely disinfect all frequently touched surfaces at least daily. Provide disinfectant wipes to wipe down keyboards, electronics, remote controls, etc.
 - For disinfection, most common EPA-registered household disinfectants should be effective. Follow the manufacturer's instructions for all cleaning and disinfection products.
- Discourage workers from using co-workers' phones, desks, offices, or other office tools and equipment, when possible. If they must use, provide disposable wipes so that commonly used surfaces (including doorknobs, remote controls, etc.) can be wiped down by between each use.

Public Health Guidance for **MASS GATHERING AREAS**

(continued)



Engineering & Environmental Controls (continued)

Improve engineering controls and perform routine environmental cleaning. Consider the following:

- Perform enhanced cleaning and disinfection after suspected cases of COVID-19 have been in the center. Close off areas used by the sick person, open outside doors and windows to increase air circulation, and wait up to 24 hours or as long as possible before cleaning to allow for respiratory droplets settle before cleaning and disinfecting.
- If curbside services are selected, patrons should remain in the vehicles and staff should remove and place materials in their trunk/back seat.
 - Libraries
 - If physical objects are being checked-out through curbside services, consideration should be given to the kinds of material and whether any could harbor COVID-19. If physical objects are being checked out within the facility, install physical barriers (plexiglass or plastic window) in locations where exchanges may occur with customers.
 - Decontamination procedures or timeframes should be developed with assistance through CDC website.
 - Disable public WiFi to curb patrons gathering outside building.
 - Places of Worship
 - Designate a flow of traffic so worshippers can move about with minimal contact.
 - Avoid practices which could spread COVID-19 such as 'passing the plate'.
 - Alter rituals that formerly required contact so they can be practiced with social distancing.
 - Community Centers
 - Designate a flow of traffic so people can move about with minimal contact.
 - Avoid practices which risk spreading COVID such as games that require touching objects (e.g., balls).



Administrative Controls

Establish administrative controls while employees and visitors are onsite. Consider the following:

- Identify a workplace coordinator who will be responsible for COVID-19 issues and their impact at the workplace.
 - Implement daily health and temperature screenings for employees upon arriving to work.
 - Provide education and training on new processes, COVID-19, and the use of PPE while in the building.
- Review Human Resource policies to make sure that policies and practices are consistent with both public health recommendations and existing state and federal workplace laws.
 - Implement flexible sick leave and supportive policies and practices.
 - Ensure that sick leave policies are flexible and consistent with public health guidance and provide employee training on new policies. If sick leave is not a benefit, it is recommended that employers draft a non-punitive emergency sick leave policy.
 - Maintain flexible policies that permit employees to stay home to care for a sick family member or take care of children due to school/daycare closures.

Public Health Guidance for **MASS GATHERING AREAS**

(continued)



Administrative Controls (continued)

**Establish administrative controls while employees and visitors are onsite.
Consider the following:**

- Review Human Resource policies to make sure that policies and practices are consistent with public health recommendations and are consistent with existing state and federal workplace laws (continued).
 - Employers should not require a positive COVID-19 test result or a healthcare provider's note for employees who are sick to validate their illness, qualify for sick leave, or to return to work.
 - Connect employees to Employee Assistance Program (EAP) resources and community resources as needed. Employees may need additional social, behavioral, and other services for mental health support.
 - Consider temporarily assigning employees at high risk for COVID-19 to duties that do not involve close contact with the public.
- Assess essential functions and the reliance that the community has on your services/products.
 - Determine how you will operate if absenteeism spikes from increases in sick employees, those who stay home to care for sick family members, and those who must stay home to watch their children. Plan to monitor and respond to absenteeism in the workplace. Implement plans to continue your essential business functions. Cross-train employees to perform essential functions so the workplace can operate even if key employees are absent.
- Messaging should be coordinated with the facility's National and State associations to ensure uniformity and accuracy, and should also reflect the most current State and CDC public health guidance.
- Employees who work with small groups within facilities that begin to reopen should be trained in practicing social distancing.
- Establish a procedures for identifying people who are symptomatic; if they are identified, they should be masked and isolated until they can leave the facility.



Personal Protective Equipment (PPE)

**Require the appropriate type of PPE for employees and customers.
Consider the following:**

- Cloth face coverings should be worn; rather than wearing gloves, hands should be washed frequently.
- Consider requiring patrons to wear cloth face coverings upon entry. Keep in mind some customers may not be able to wear face coverings due to medical conditions. For this reason, be mindful of discriminatory behavior from staff or customers.

Public Health Guidance for **CHILDCARE PROGRAMS**



Conduct Risk Assessment

Establish critical protective guidelines. Consider the following questions:

- Are there locations where employees routinely congregate?
- Are tools and equipment frequently shared by multiple employees?
- Does customer flow allow for social distancing measures?
- Where are areas in your business that would not allow customers and staff to properly distance?
- Who are your high risk employees?
- Is your business actively engaged in activities that promote disease transmission?
- Does your business have existing cleaning and disinfecting procedures?
- How quickly can you communicate with employees?
- Are communication resources needed in multiple languages?

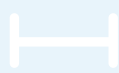

Physical Distancing

Establish policies and procedures for social distancing. Consider the following:

- Child care classes should include the same group each day, and the same providers should remain with the same group each day. If program remains open, consider creating a separate classroom or group for the children of essential workers and other first responders. If your program is unable to create a separate classroom, consider serving only the children of essential/first responder workers.
- Consider staggering arrival and drop off times; offer curbside assistance where providers come outside the facility to pick up children as they arrive.
- Cancel or postpone special events such as performances, festivals, holiday events, etc.
- Limit the mixing of children, such as staggering playground times and keeping groups separate for special activities such as art, music, and exercising.
- At nap time, ensure that children's nap time mats (or cribs) are spaced out as much as possible, ideally six feet. Consider placing children head to toe to further reduce the potential for viral spread.



Engineering & Environmental Controls

Improve engineering controls and perform routine environmental cleaning. Consider the following:

- Increase ventilation rates and percentage of outdoor air that circulates into the system.
- Support respiratory etiquette and hand hygiene for employees and children:
 - Provide tissues, no-touch disposal receptacles, and soap and water in the center (if not readily available, use alcohol-based hand sanitizer that is at least 60% alcohol). Ensure adequate supplies are maintained and place hand sanitizers in multiple locations.
 - Place posters that encourage hand hygiene to help stop the spread of COVID-19 at the entrance to your workplace and in other areas where they are likely to be seen.
 - Discourage handshaking – encourage the use of other non-contact methods of greeting.
 - Direct employees to visit CDC website for information on coughing and sneezing etiquette and handwashing.

Public Health Guidance for **CHILDCARE PROGRAMS**

(continued)



Engineering & Environmental Controls (continued)

Improve engineering controls and perform routine environmental cleaning. Consider the following:

- Perform routine environmental cleaning and disinfection.
 - Routinely disinfect all frequently touched surfaces at least daily, especially toys and games; Provide disinfectant wipes to wipe down keyboards, electronics, remote controls, etc.
 - For disinfection, most common EPA-registered household disinfectants should be effective. Follow the manufacturer's instructions for all cleaning and disinfection products.
- Plan to have an isolation room or area that can be used to isolate a sick child before the parent can arrive to take them home.
- Install physical barriers (plexiglass or plastic window) in locations where parent may sign children in/out and where health monitoring/temperature checks occur.
- Perform enhanced disinfection after suspected cases of COVID-19 have been in the center. Close off areas used by the sick person, open outside doors and windows to increase air circulation, and wait up to 24 hours or as long as possible before cleaning to allow for respiratory droplets settle before cleaning and disinfecting.



Administrative Controls

Establish administrative controls while employees and visitors are onsite. Consider the following:

- Identify a workplace coordinator who will be responsible for COVID-19 issues and their impact at the center.
 - Implement daily health and temperature screenings for employee and children upon arrival to the center.
 - Encourage parents to be on the alert for signs of illness in their children and to keep them home when they are sick.
 - Provide education and training on new processes, COVID-19, and the use of PPE while in the building.
- Review Human Resource policies to make sure that policies and practices are consistent with both public health recommendations and existing state and federal workplace laws.
 - Establish procedures to ensure children and staff who come to the center sick or become sick while at the center are sent home as soon as possible.
 - Implement flexible sick leave and supportive policies and practices.
 - Ensure that sick leave policies are flexible and consistent with public health guidance and provide employee training on new policies. If sick leave is not a benefit, it is recommended that employers draft a non-punitive emergency sick leave policy.
 - Maintain flexible policies that permit employees to stay home to care for a sick family member or take care of children due to school/daycare closures.
 - Employers should not require a positive COVID-19 test result or a healthcare provider's note for employees who are sick to validate their illness, qualify for sick leave, or to return to work.
 - Connect employees to Employee Assistance Program (EAP) resources and community resources as needed. Employees may need additional social, behavioral, and other services for mental health support.

Public Health Guidance for **CHILDCARE PROGRAMS**

(continued)



Administrative Controls (continued)

**Establish administrative controls while employees and visitors are onsite.
Consider the following:**

- Review Human Resource policies to make sure that policies and practices are consistent with both public health recommendations and existing state and federal workplace laws (continued).
 - Consider temporarily assigning employees at high risk for virus to duties that do not involve close contact with the public.
 - Communicate to staff the importance of being vigilant for symptoms and staying in touch with facility management if or when they start to feel sick.
- Assess essential functions and the reliance that the community has on your services/products.
 - Talk with companies that provide your business with contract or temporary employees about the importance of sick employees staying home and encourage them to develop non-punitive leave policies.
 - Determine how you will operate if absenteeism spikes from increases in sick employees, those who stay home to care for sick family members, and those who must stay home to watch their children. Plan to monitor and respond to absenteeism in the workplace. Implement plans to continue your essential business functions. Cross-train employees to perform essential functions so the workplace can operate even if key employees are absent.
- Maintain an adequate ratio of staff to children to ensure safety.
- Communicate to parents the importance of keeping children home when they are sick. Sick staff members and children should not return to facility until they have met the criteria to discontinue home isolation.



Personal Protective Equipment (PPE)

**Require the appropriate type of PPE for employees and customers.
Consider the following:**

- Cloth face coverings should be worn at all times; cloth face coverings should not be put on babies and children under the age of 2 because of the dangers of suffocation.
- Gloves should be worn when cleaning and disinfecting as well as during meal prep/serving.

Public Health Guidance for K-12 SCHOOLS



Conduct Risk Assessment

Establish critical protective guidelines. Consider the following questions:

- Are there locations where employees routinely congregate?
- Are tools and equipment frequently shared by multiple employees?
- Does customer flow allow for social distancing measures?
- Where are areas in your business that would not allow customers and staff to properly distance?
- Who are your high risk employees?
- Is your business actively engaged in activities that promote disease transmission?
- Does your business have existing cleaning and disinfecting procedures?
- How quickly can you communicate with employees?
- Are communication resources needed in multiple languages?



Physical Distancing

Establish policies and procedures for social distancing. Consider the following:

- Ensure staff and students limit close contact (stay six feet apart). Appoint a staff/security person who will ensure that people standing in any lines or meeting in rooms maintain physical distance.
- In areas of high-volume traffic, utilize spacing tools for social distancing screenings and lines (e.g., place tape on floor to keep people adequately spaced; place arrows in the aisle to direct the flow of movement in one direction).
- Rearrange student desks to accommodate appropriate social distancing measures.
- Assess group gatherings and events; consider postponing non-critical gatherings and events (e.g., assemblies, field days, spirit nights, athletic events).
- Establish staggered lunch and break times for students and staff.



Engineering & Environmental Controls

Improve engineering controls and perform routine environmental cleaning. Consider the following:

- Increase ventilation rates and percentage of outdoor air that circulates into the system.
- Support respiratory etiquette and hand hygiene for employees, students and visitors:
 - Provide tissues, no-touch disposal receptacles, and soap and water in the workplace (if not readily available, use alcohol-based hand sanitizer that is at least 60% alcohol). Ensure adequate supplies are maintained and place hand sanitizers in multiple locations.
 - Install touchless soap and hand sanitizer dispensers; regular hand hygiene should be built into the daily routine.
 - Place posters that encourage hand hygiene to help stop the spread COVID-19 at the entrance to your building and in other areas where they are likely to be seen.
 - Discourage handshaking – encourage the use of other non-contact methods of greeting.
 - Direct employees to visit CDC website for information on coughing and sneezing etiquette and handwashing.

Public Health Guidance for K-12 SCHOOLS

(continued)



Engineering & Environmental Controls (continued)

Improve engineering controls and perform routine environmental cleaning. Consider the following:

- Perform routine environmental cleaning and disinfection.
 - Routinely disinfect all frequently touched surfaces in the workplace, such as workstations, keyboards, telephones, handrails, doorknobs, light switches, classroom sink handles, and countertops.
 - For disinfection, most common EPA-registered household disinfectants should be effective. Follow the manufacturer's instructions for all cleaning and disinfection products.
 - Provide EPA approved-disposable wipes to teachers and staff so commonly used surfaces (e.g., keyboards, desks, remote controls) can be wiped down before and after use.
 - Place touchless hand sanitizing units in entrances to building, cafeteria, and areas where soap and water is not available.
- Perform enhanced cleaning and disinfection after suspected cases of COVID-19 has been in the facility.
- Consider having students eat meals in the classrooms or in smaller cohorts in the lunch room while maintaining social distancing measures.
- Create a separate room for sick children to be in while waiting for a caregiver to pick them up if they become ill during the school day.
- Rearrange student desks to maximize space between students; turn desks to face the same direction (rather than face each other) to reduce transmission of virus droplets.



Administrative Controls

Establish administrative controls while employees and visitors are onsite. Consider the following:

- Implement your annual seasonal influenza plan; students and staff that are ill, especially with fever and/or acute respiratory symptoms should stay home.
- Review attendance and sick leave policies. Encourage students and staff to stay home when sick, even without documentation from doctors. Use flexibility, when possible, to allow staff to stay home to care for sick family members.
- Remind students to cover their coughs and sneezes with a tissue or their elbow; ensure hygiene posters are posted in highly visible areas.
- Ensure parents/guardians have a plan to designate a caregiver (someone under the age of 60) for a sick child if parent can't stay home.
- Look for opportunities to address food insecurities for families who rely on schools for breakfast/lunch.
- Avoid assemblies and multiple class activities to limit non-essential contact between students in large gatherings.
- Consider canceling or postponing events that bring groups of families and students into more frequent contact with each other; provide teacher conferences through zoom or by appointment to minimize waiting in line.
- Limit the presence of volunteers for classroom activities, cafeteria support, and other activities.
- Limit cross-school transfers for special programs; consider using distance learning to deliver the instruction or temporarily offering duplicate programs in participating schools.

Public Health Guidance for K-12 SCHOOLS

(continued)



Administrative Controls (continued)

**Establish administrative controls while employees and visitors are onsite.
Consider the following:**

- Assess essential functions and the reliance that the community has on your services/products (continued).
 - Determine how you will operate if absenteeism spikes from increases in sick employees, those who stay home to care for sick family members, and those who must stay home to watch their children. Plan to monitor and respond to absenteeism in the workplace. Implement plans to continue your essential business functions. Prepare to institute flexible workplace and leave policies. Cross-train employees to perform essential functions so the workplace can operate even if key employees are absent.



Personal Protective Equipment (PPE)

**Require the appropriate type of PPE for employees and customers.
Consider the following:**

- Cloth face coverings should be worn at all times by students and school staff (teachers, administrators, security, etc.).
- Gloves can be worn as necessary.

Public Health Guidance for COLLEGES & UNIVERSITIES



Conduct Risk Assessment

Establish critical protective guidelines. Consider the following questions:

- Are there locations where employees routinely congregate?
- Are tools and equipment frequently shared by multiple employees?
- Does customer flow allow for social distancing measures?
- Where are areas in your business that would not allow customers and staff to properly distance?
- Who are your high risk employees?
- Is your business actively engaged in activities that promote disease transmission?
- Does your business have existing cleaning and disinfecting procedures?
- How quickly can you communicate with employees?
- Are communication resources needed in multiple languages?



Physical Distancing

Establish policies and procedures for social distancing. Consider the following:

- Maintain a safe social distance of six feet or more in all settings, including meetings.
- Meeting sizes, in terms of number of participants, should be kept to a minimum in order to maintain safe social distance of six feet.
- Meeting venue should be large enough to accommodate the six feet minimum social distancing.
- In areas of high-volume traffic, utilize spacing tools for social distancing screenings and lines (e.g., place tape on floor to keep people adequately spaced; place arrows in the aisle to direct the flow of movement in one direction).
- Rearrange student desks/workstations to accommodate appropriate social distancing measures.
- Limit cafeteria and snack area tables and chairs to minimize congregation of students.



Engineering & Environmental Controls

Improve engineering controls and perform routine environmental cleaning. Consider the following:

- Increase ventilation rates and percentage of outdoor air that circulates into the system.
- Support respiratory etiquette and hand hygiene for employees, students, and visitors by:
 - Provide tissues, no-touch disposal receptacles, and soap and water in the workplace (if not readily available, use alcohol-based hand sanitizer that is at least 60% alcohol). Ensure adequate supplies are maintained and place hand sanitizers in multiple locations.
 - Place posters that encourage hand hygiene to help stop the spread of COVID-19 at the entrance to your building and in other areas where they are likely to be seen.
 - Discourage handshaking – encourage the use of other non-contact methods of greeting.
 - Direct employees and students to visit CDC website for information on coughing and sneezing etiquette and handwashing.

Public Health Guidance for COLLEGES & UNIVERSITIES

(continued)



Engineering & Environmental Controls (continued)

Improve engineering controls and perform routine environmental cleaning.

Consider the following:

- Perform routine environmental cleaning and disinfection.
 - Routinely disinfect all frequently touched surfaces in the workplace, such as workstations, keyboards, telephones, handrails, and doorknobs.
 - Cleaning staff should clean and disinfect all areas (e.g., offices, bathrooms, and common areas) used by staff and students focusing especially on frequently touched surfaces; if surfaces are dirty, they should be cleaned using a detergent or soap and water prior to disinfection. For disinfection, most common EPA-registered household disinfectants should be effective. Follow the manufacturer's instructions for all cleaning and disinfection products.
- Discourage workers and students from using others' phones, desks, offices, or other office tools and equipment, when possible. If they must use, provide disposable wipes so that commonly used surfaces (including doorknobs, remote controls, etc.) can be wiped down between each use.
- Perform enhanced cleaning and disinfection after suspected cases of COVID-19 has been in the building.
- Use of existing infrastructure and services (e.g., Blackboard, Skype, Zoom) to support efficient transition of classes from in-person to distance-based formats. This may include using strategies such as faculty check-ins, recorded class meetings or lectures, and live class meetings.
- Other student support services such as online library services, print materials available online, phone- or Internet-based counseling support, or study groups enabled through digital media.
- Consider using webinar hybrid classes; offer an in-person class as well as live stream via a webinar service at the same time. Participants would need to pre-register.
- To avoid lines and waiting time, encourage participants to call ahead to register for classes; ideally take payment information over the phone or invest in a touchless payment system.
- Install physical barriers (plexiglass or plastic window) in areas that would minimize direct face-to-face interaction.



Administrative Controls

Establish administrative controls while employees and visitors are onsite.

Consider the following:

- Identify a workplace coordinator who will be responsible for COVID-19 issues and their impact at the workplace
 - Implement daily health and temperature screenings for employees upon arriving to work.
- Review Human Resource policies to make sure that policies and practices are consistent with both public health recommendations and existing state and federal workplace laws.
 - Implement flexible sick leave and supportive policies and practices.
 - Ensure that sick leave policies are flexible and consistent with public health guidance and provide employee training on new policies. If sick leave is not a benefit, it is recommended that the employer draft a non-punitive emergency sick leave policy.
 - Maintain flexible policies that permit employees to stay home to care for a sick family member or take care of children due to school/daycare closures.

Public Health Guidance for COLLEGES & UNIVERSITIES

(continued)



Administrative Controls (continued)

**Establish administrative controls while employees and visitors are onsite.
Consider the following:**

- Review Human Resource policies to make sure that policies and practices are consistent with both public health recommendations and existing state and federal workplace laws (continued).
 - Employers should not require a positive COVID-19 test result or a healthcare provider's note for employees who are sick to validate their illness, qualify for sick leave, or to return to work.
 - Connect employees to Employee Assistance Program (EAP) resources and community resources as needed. Employees may need additional social, behavioral, and other services for mental health support.
 - Encourage students and staff to stay home when sick, even without documentation from doctors. Use flexibility, when possible, to allow staff to stay home to care for sick family members.
- Assess essential functions and the reliance the community has on your services/products.
 - Talk with companies that provide your business with contract or temporary employees about the importance of sick employees staying home and encourage them to develop non-punitive leave policies.
 - Determine how you will operate if absenteeism spikes from increases in sick employees, those who stay home to care for sick family members, and those who must stay home to watch their children. Plan to monitor and respond to absenteeism in the workplace. Implement plans to continue your essential business functions. Prepare to institute flexible workplace and leave policies. Cross-train employees to perform essential functions so the workplace can operate even if key employees are absent.
- Ensure the emergency operation plan emphasizes everyday preventive actions for students and staff.
- Test communication capacity, and reiterate steps staff and students can take to stay healthy.
- Identify critical job functions and positions, and plan for alternative coverage by cross-training staff.



Personal Protective Equipment (PPE)

**Require the appropriate type of PPE for employees and customers.
Consider the following:**

- Cloth face coverings should be worn at all times by students and school staff (teachers, administrators, security, etc.).
- Gloves can be worn as necessary.

Public Health Guidance for AIRPORTS



Conduct Risk Assessment

Establish critical protective guidelines. Consider the following questions:

- Are there locations where employees routinely congregate?
- Are tools and equipment frequently shared by multiple employees?
- Does customer flow allow for social distancing measures?
- Where are areas in your business that would not allow customers and staff to properly distance?
- Who are your high risk employees?
- Is your business actively engaged in activities that promote disease transmission?
- Does your business have existing cleaning and disinfecting procedures?
- How quickly can you communicate with employees?
- Are communication resources needed in multiple languages?



Physical Distancing

Establish policies and procedures for social distancing. Consider the following:

- Increase physical space between employees at the worksite, and between employees and customers – especially in waiting rooms. Install plastic shields between reception staff and visitors.
- Consider downsizing operations.
- Limit the number of people in elevators, bathroom, meeting spaces, and other common spaces; consider reconfiguring office spaces and environment.



Engineering & Environmental Controls

Improve engineering controls and perform routine environmental cleaning. Consider the following:

- Increase ventilation rates and percentage of outdoor air that circulates into the system.
- Support respiratory etiquette and hand hygiene for employees, customers, and visitors by:
 - Provide tissues, no-touch disposal receptacles, and soap and water in the workplace (if not readily available, use alcohol-based hand sanitizer that is at least 60% alcohol). Ensure adequate supplies are maintained and place hand sanitizers in multiple locations.
 - Place posters that encourage hand hygiene to help stop the spread of COVID-19 at the entrance to your workplace and in other areas where they are likely to be seen.
 - Discourage handshaking – encourage the use of other non-contact methods of greeting.
 - Direct employees to visit CDC website for information on coughing and sneezing etiquette and handwashing
- Perform routine environmental cleaning and disinfection.
 - Routinely disinfect all frequently touched surfaces in employee breakroom and airport, such as wheelchair handles, motorized carts, other transportation and assistive devices, and communication systems such as two-way radios, tablets, or other mobile devices. Provide disinfectant wipes to clean common areas.
 - For disinfection, most common EPA-registered household disinfectants should be effective. Follow the manufacturer's instructions for all cleaning and disinfection products.

Public Health Guidance for AIRPORTS

(continued)



Engineering & Environmental Controls (continued)

Improve engineering controls and perform routine environmental cleaning. Consider the following:

- Discourage workers from using co-workers' phones, desks, offices, or other office tools and equipment, when possible. If they must use, provide disposable wipes so that commonly used surfaces (including doorknobs, remote controls, etc.) can be wiped down by between each use.
- Perform enhanced cleaning and disinfection after suspected cases of have COVID-19 has been in the facility.



Administrative Controls

Establish administrative controls while employees and visitors are onsite. Consider the following:

- Identify a workplace coordinator who will be responsible for COVID-19 issues and their impact at the workplace.
 - Implement daily health and temperature screenings for employees upon arriving to work.
 - Employees should know who the workplace coordinator is and how to contact them.
- Review Human Resource policies to make sure that policies and practices are consistent with both public health recommendations and existing state and federal workplace laws.
 - Implement flexible sick leave and supportive policies and practices.
 - Ensure that sick leave policies are flexible and consistent with public health guidance and provide employee training on new policies. If sick leave is not a benefit, it is recommended that the employer draft a non-punitive emergency sick leave policy.
 - Maintain flexible policies that permit employees to stay home to care for a sick family member or take care of children due to school/daycare closures.
 - Employers should not require a positive COVID-19 test result or a healthcare provider's note for employees who are sick to validate their illness, qualify for sick leave, or to return to work.
 - Connect employees to Employee Assistance Program (EAP) resources and community resources as needed. Employees may need additional social, behavioral, and other services for mental health support.
- Assess essential functions and the reliance that the community has on your services/products.
 - Be prepared to change your business practices, if needed, to maintain critical operations (e.g., identify alternative suppliers, prioritize existing customers, or temporarily suspend some of your operations if needed).
 - Identify alternate supply chains for critical goods and services as some may be in higher demand or unavailable.
 - Talk with companies that provide your business with contract or temporary employees about the importance of sick employees staying home and encourage them to develop non-punitive leave policies.
 - Talk with business partners about response plans. Share best practices with other businesses in your communities (especially in your supply chain), Chambers of Commerce, and associations to improve community response efforts.

Public Health Guidance for AIRPORTS

(continued)



Administrative Controls (continued)

**Establish administrative controls while employees and visitors are onsite.
Consider the following:**

- Assess essential functions and the reliance that others and the community have on your services/products (continued).
 - Determine how you will operate if absenteeism spikes from increases in sick employees, those who stay home to care for sick family members, and those who must stay home to watch their children. Plan to monitor and respond to absenteeism in the workplace. Implement plans to continue your essential business functions. Prepare to institute flexible workplace and leave policies. Cross-train employees to perform essential functions so the workplace can operate even if key employees are absent.



Personal Protective Equipment (PPE)

**Require the appropriate type of PPE for employees and customers.
Consider the following:**

- Wear cloth face coverings when social distancing not easy to maintain.
- Use gloves when removing garbage bags or handling and disposing of trash; use when disinfecting frequently touched areas; wash hands afterwards.

Public Health Guidance for **BUS TRANSIT**



Conduct Risk Assessment

Establish critical protective guidelines. Consider the following questions:

- Are there locations where employees routinely congregate?
- Are tools and equipment frequently shared by multiple employees?
- Does customer flow allow for social distancing measures?
- Where are areas in your business that would not allow customers and staff to properly distance?
- Who are your high risk employees?
- Is your business actively engaged in activities that promote disease transmission?
- Does your business have existing cleaning and disinfecting procedures?
- How quickly can you communicate with employees?
- Are communication resources needed in multiple languages?



Physical Distancing

Establish policies and procedures for social distancing. Consider the following:

- Limit close contact with others by maintaining a distance of at least six feet, when possible.
- Consider asking bus passengers to enter and exit the bus through rear entry doors.
- Request passengers avoid standing or sitting within six feet of bus driver.
- Close every other row of seats.



Engineering & Environmental Controls

Improve engineering controls and perform routine environmental cleaning. Consider the following:

- Support respiratory etiquette and hand hygiene for employees and customers:
 - Provide tissues, no-touch disposal receptacles, and soap and water in the workplace (if not readily available, use alcohol-based hand sanitizer that is at least 60% alcohol). Ensure adequate supplies are maintained and place hand sanitizers in multiple locations.
 - Place posters that encourage hand hygiene to help stop the spread of COVID-19 at the entrance to your workplace and in other areas where they are likely to be seen.
 - Discourage handshaking – encourage the use of other non-contact methods of greeting.
 - Direct employees to visit CDC website for information on coughing and sneezing etiquette and handwashing
- Perform routine environmental cleaning and disinfection.
 - Routinely disinfect all frequently touched surfaces, including surfaces in the driver cockpit commonly touched by the operator.
 - For disinfection, most common EPA-registered household disinfectants should be effective. Follow the manufacturer's instructions for all cleaning and disinfection products.
- Institute measures to physically separate bus operator from passengers by use of physical partitions or visual cues (floor decals, signs, colored tape).
- Install physical barriers such as plastic guards and partitions at staffed kiosks and on transit vehicles to the extent practicable.

Public Health Guidance for **BUS TRANSIT**

(continued)



Engineering & Environmental Controls (continued)

Improve engineering controls and perform routine environmental cleaning.

Consider the following:

- Use touchless payment and no-touch trash cans and doors as much as possible, when available. Ask customers and employees to exchange cash or credit cards by placing in a receipt tray or on the counter rather than by hand and wipe any pens, counters, or hard surfaces between each use or customer.
- Avoid using or sharing items that are not easily cleaned, sanitized or disinfected, such as disposable transit maps
- Ensure that ventilation systems operate properly and increase circulation of outdoor air as much as possible by opening windows and doors at transit center.



Administrative Controls

Establish administrative controls while employees and visitors are onsite.

Consider the following:

- Identify a workplace coordinator who will be responsible for COVID-19 issues and their impact at the workplace.
 - Implement daily health and temperature screenings for employees upon arriving to work.
 - Employees should know who the workplace coordinator is and how to contact them.
- Review Human Resource policies to make sure that policies and practices are consistent with both public health recommendations and existing state and federal workplace laws.
 - Implement flexible sick leave and supportive policies and practices.
 - Ensure that sick leave policies are flexible and consistent with public health guidance and provide employee training on new policies. If sick leave is not a benefit, it is recommended that the employer draft a non-punitive emergency sick leave policy.
 - Maintain flexible policies that permit employees to stay home to care for a sick family member or take care of children due to school/daycare closures.
 - Employers should not require a positive COVID-19 test result or a healthcare provider's note for employees who are sick to validate their illness, qualify for sick leave, or to return to work.
 - Connect employees to Employee Assistance Program (EAP) resources and community resources as needed. Employees may need additional social, behavioral, and other services for mental health support.
 - Actively encourage sick employees to stay home. Sick employees should not return to work until criteria to discontinue home isolation is met.
- Assess essential functions and the reliance that the community has on your services/products.
 - Be prepared to change your business practices, if needed, to maintain critical operations.
 - Identify alternate supply chains for critical goods and services as some may be in higher demand or unavailable.
 - Talk with companies that provide your business with contract or temporary employees about the importance of sick employees staying home and encourage them to develop non-punitive leave policies.

Public Health Guidance for **BUS TRANSIT**

(continued)



Administrative Controls (continued)

**Establish administrative controls while employees and visitors are onsite.
Consider the following:**

- Assess essential functions and the reliance that the community has on your services/products (continued).
 - Determine how you will operate if absenteeism spikes from increases in sick employees, those who stay home to care for sick family members, and those who must stay home to watch their children. Plan to monitor and respond to absenteeism in the workplace. Implement plans to continue your essential business functions. Prepare to institute flexible workplace and leave policies. Cross-train employees to perform essential functions so the workplace can operate even if key employees are absent.



Personal Protective Equipment (PPE)

**Require the appropriate type of PPE for employees and customers.
Consider the following:**

- Wear cloth face coverings when social distancing not easy to maintain.
- Use gloves when removing garbage bags or handling and disposing of trash; use when disinfecting frequently touched areas; wash hands afterwards.

Public Health Guidance for Rideshare

Taxi | Limo | Lyft | Uber



Conduct Risk Assessment

Establish critical protective guidelines. Consider the following questions:

- Are there locations where employees routinely congregate?
- Are tools and equipment frequently shared by multiple employees?
- Does customer flow allow for social distancing measures?
- Where are areas in your business that would not allow customers and staff to properly distance?
- Who are your high risk employees?
- Is your business actively engaged in activities that promote disease transmission?
- Does your business have existing cleaning and disinfecting procedures?
- How quickly can you communicate with employees?
- Are communication resources needed in multiple languages?



Physical Distancing

Establish policies and procedures for social distancing. Consider the following:

- Avoid providing pooled rides or picking up multiple passengers who would not otherwise together on the same route.
- Tell passenger to sit in the back seat; do not let passengers sit in the front seat.
- Keep a distance of at least six feet from passengers when you are outside the vehicle.
- Ask passengers to sit six feet from driver when transporting passengers in larger vehicles such as vans and buses.
- Consider asking passengers to handle their own personal bags and belongings during pick-up and drop-off.



Engineering & Environmental Controls

Improve engineering controls and perform routine environmental cleaning.

Consider the following:

- Support respiratory etiquette and hand hygiene for yourself and customers:
 - Consider providing tissues and alcohol-based hand sanitizer that is at least 60% alcohol).
 - Discourage handshaking – encourage the use of other non-contact methods of greeting.
- Perform routine environmental cleaning and disinfection.
 - Routinely disinfect all frequently touched surfaces, including door frames/handles, windows, seat belt buckles, steering wheel, gearshift, signaling levers, and other vehicle parts at a minimum before shift, after shift, and when transporting any sick passenger.
- For disinfection, most common EPA-registered household disinfectants should be effective. Follow the manufacturer's instructions for all cleaning and disinfection products.
- Implement touch-free options to pay for services; utilize iPhone apps; minimize handling/exchanging money.
- Avoid using or sharing items that are not easily cleaned, sanitized, or disinfected.
- Ensure that ventilation systems operate properly and increase circulation of outdoor air as much as possible by opening windows and doors. Avoid using the recirculated air option for the car's ventilation during passenger transport; use car's vents to bring in fresh outside air and/or lower the vehicle windows.

Public Health Guidance for RIDESHARE

(continued)



Administrative Controls

**Establish administrative controls while employees and visitors are onsite.
Consider the following:**

- Actively encourage sick drivers to stay home.
- Provide employees with where to find accurate information about COVID-19, its symptoms, and how it spreads.
- Encourage the use of and provide assistance in acquiring hand sanitizer and disposable wipes and cleaning products so that commonly touched vehicle surfaces can be wiped down by drivers.
- Develop policies and technology options that allow and prioritize contactless transactions that limit or eliminate close contact and the sharing of items such as pens and electronic signature pads between drivers and passengers.



Personal Protective Equipment (PPE)

**Require the appropriate type of PPE for employees and customers.
Consider the following:**

- Wear cloth face coverings when social distancing is not easy to maintain.
- Use gloves when cleaning and disinfecting frequently touched surfaces.

Public Health Guidance for SENIOR FACILITIES

Senior Centers | Adult Day Care Centers



Conduct Risk Assessment

Establish critical protective guidelines. Consider the following questions:

- Are there locations where employees routinely congregate?
- Are tools and equipment frequently shared by multiple employees?
- Does customer flow allow for social distancing measures?
- Where are areas in your business that would not allow customers and staff to properly distance?
- Who are your high risk employees?
- Is your business actively engaged in activities that promote disease transmission?
- Does your business have existing cleaning and disinfecting procedures?
- How quickly can you communicate with employees?
- Are communication resources needed in multiple languages?

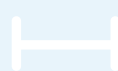

Physical Distancing

Establish policies and procedures for social distancing. Consider the following:

- Increase physical space between employees and customers, at least 8 feet apart (this allows a person to be standing next to their chair but still following social distancing recommendations).
- In areas of high traffic, utilize spacing tools for social distancing screenings and lines (e.g., place tape on floor to keep people adequately spaced; place arrows in aisle to direct flow of movement in one direction).
- Limit the number of people visiting the center or engaging in social events. Current guidelines is for sites <50,000 sq. ft. to allow 25% of maximum occupancy to be in the building at one time (e.g., if your largest room is capped at 300 people, you now can only allow 75 people).
- Remove lounge chairs/couches to increase distancing requirements and minimize congregation of people.
- Rearrange board and conference room configurations to meet distancing guidelines.
- Establish staggered lunches and break times for staff.
- Provide services by appointment, if possible.
- Social clubs, group activities, travel, and table/board games should be discouraged until Phase 3.
- Replace face-to-face meetings with virtual or phone meetings.



Engineering & Environmental Controls

Improve engineering controls and perform routine environmental cleaning. Consider the following:

- Increase ventilation rates and percentage of outdoor air that circulates into the system.
- Support respiratory etiquette and hand hygiene for employees, residents and visitors:
 - Provide tissues, no-touch disposal receptacles, and soap and water in the center (if not readily available, use alcohol-based hand sanitizer that is at least 60% alcohol). Ensure adequate supplies are maintained and place hand sanitizers in multiple locations.
 - Place posters that encourage hand hygiene to help stop the spread of COVID-19 at the entrance to your workplace and in other areas where they are likely to be seen.

Public Health Guidance for SENIOR FACILITIES

(continued)



Engineering & Environmental Controls (continued)

Improve engineering controls and perform routine environmental cleaning. Consider the following:

- Support respiratory etiquette and hand hygiene for employees, residents and visitors (continued):
 - Discourage handshaking – encourage the use of other non-contact methods of greeting.
 - Direct employees to visit CDC website for information on coughing and sneezing etiquette and handwashing.
- Perform routine environmental cleaning and disinfection.
 - Routinely disinfect all frequently touched surfaces at least daily, especially keyboards, electronics, remote controls, games and door handles; Provide disinfectant wipes to wipe down items.
 - For disinfection, most common EPA-registered household disinfectants should be effective. Follow the manufacturer’s instructions for all cleaning and disinfection products.
- Perform enhanced disinfection after suspected cases of COVID-19 have been in the center. Close off areas used by the sick person, open outside doors and windows to increase air circulation, and wait up to 24 hours or as long as possible before cleaning to allow for respiratory droplets settle before cleaning and disinfecting.
- Install physical barriers (plexiglass or plastic window) in locations where visitors check in and where health monitoring/temperature checks occur.
- To avoid lines and waiting time, encourage participants to call ahead to register for classes; ideally take payment information over the phone or invest in a touchless payment system.
- Consider using webinar hybrid classes; offer an in-person class as well as live stream via a webinar service at the same time. Participants would need to pre-register.
- Avoid practices which risk spreading COVID-19, such as games that require touching objects (cards, board games, puzzles).
- Water fountains should be shut off or blocked and water pitchers should not be available in common areas; consider offering bottled water or encourage participants to bring their own.
- If serving meals, grab-and-go lunches should be available; pick up for meals should include social distancing measures.
- Transportation: any rider should be health/temperature screened prior to entering vehicle; driver should wear face covering and face shield if plastic barriers are not in place; riders should all wear face coverings.



Administrative Controls

Establish administrative controls while employees and visitors are onsite. Consider the following:

- Identify a workplace coordinator who will be responsible for COVID-19 issues and their impact at the center.
 - Implement daily health and temperature screenings for employees upon arrival to the center.
 - Encourage staff to be on the alert for signs of illness in the residents or visitors.
 - Provide education and training on new processes, COVID-19, and the use of PPE while in the building.
- Review Human Resource policies to make sure that policies and practices are consistent with both public health recommendations and existing state and federal workplace laws.
 - Establish procedures to ensure staff, residents or visitors who come to the center sick or become sick while at the center are sent home as soon as possible.

Public Health Guidance for SENIOR FACILITIES

(continued)



Administrative Controls (continued)

**Establish administrative controls while employees and visitors are onsite.
Consider the following:**

- Review Human Resource policies to make sure that policies and practices are consistent with both public health recommendations and existing state and federal workplace laws (continued).
 - Implement flexible sick leave and supportive policies and practices.
 - Ensure that sick leave policies are flexible and consistent with public health guidance and provide employee training on new policies. If sick leave is not a benefit, it is recommended that employers draft a non-punitive emergency sick leave policy.
 - Maintain flexible policies that permit employees to stay home to care for a sick family member or take care of children due to school/daycare closures.
 - Employers should not require a positive COVID-19 test result or a healthcare provider's note for employees who are sick to validate their illness, qualify for sick leave, or to return to work.
 - Connect employees to Employee Assistance Program (EAP) resources and community resources as needed. Employees may need additional social, behavioral, and other services for mental health support.
 - Consider temporarily assigning employees at high risk for COVID-19 to duties that do not involve close contact with the public.
 - Communicate to staff the importance of being vigilant for symptoms and staying in touch with facility management if or when they start to feel sick.
- Assess essential functions and the reliance that the community has on your services/products.
 - Bring staff back at least a week prior to reopening the Senior Center; this allows for training staff on new policies/procedures, rearranging site's seating and rooms, and other pertinent activities.
 - Volunteers are an important part of staffing, include them in 'retraining' as you phase in opening your activities.
 - Talk with companies that provide your business with contract or temporary employees about the importance of sick employees staying home and encourage them to develop non-punitive leave policies.
 - Determine how you will operate if absenteeism spikes from increases in sick employees, those who stay home to care for sick family members, and those who must stay home to watch their children. Plan to monitor and respond to absenteeism in the workplace. Implement plans to continue your essential business functions. Cross-train employees to perform essential functions so the workplace can operate even if key employees are absent.
- Maintain an adequate ratio of staff to residents to ensure safety.
- Reopening is suggested in a three-phased approach. Plan to run phases for at least two weeks before relaxing additional restrictions. If any visitor/staff is diagnosed with COVID-19 after visiting the Center, the Center should consider closing all program for two weeks (recommended quarantine length), and then starting again with phase one.

Public Health Guidance for SENIOR FACILITIES

(continued)



Personal Protective Equipment (PPE)

Require the appropriate type of PPE for employees and customers.

Consider the following:

- Cloth face coverings should be worn by employees and visitors at all times; offer education on face covering and wearing hygiene as needed.
- Offer cloth face coverings to visitors, as needed.
- Gloves, face shields, gowns, and other PPE can be worn as staff and visitors feel appropriate and/or comfortable, but these are not enforced.

Public Health Guidance for **VULNERABLE WORKERS**



Conduct Risk Assessment

Establish critical protective guidelines. Consider the following questions:

- Are there locations where employees routinely congregate?
- Are tools and equipment frequently shared by multiple employees?
- Does customer flow allow for social distancing measures?
- Where are areas in your business that would not allow customers and staff to properly distance?
- Who are your high risk employees?
- Is your business actively engaged in activities that promote disease transmission?
- Does your business have existing cleaning and disinfecting procedures?
- How quickly can you communicate with employees?
- Are communication resources needed in multiple languages?



Physical Distancing

Establish policies and procedures for social distancing. Consider the following:

- Limit service to drive-thru, curbside takeout, or delivery options, if possible (Phase 1).
- Consider installing physical barriers, such as plastic guards or partitions, and changing workspace layouts to ensure all individuals remain at least six feet apart.
- Close communal spaces, such as break rooms, if possible or stagger use and clean and disinfect in between uses.
- Encourage telework for as many employees as possible.
- Consider rotating or staggering shifts to limit the number of employees in the workplace at the same time.
- Replace in-person meetings with video- or tele-conference calls whenever possible.
- Cancel all group events, gatherings, or meeting of more than 10 people (Phase 1), or more than 50 people (Phase 2), and any events where social distancing of at least six feet cannot be maintained between participants (all Phases).
- Limit any sharing of food, tools, equipment, or supplies.



Engineering & Environmental Controls

Improve engineering controls and perform routine environmental cleaning.

Consider the following:

- Increase ventilation rates and percentage of outdoor air that circulates into the system.
- Support respiratory etiquette and hand hygiene for employees:
 - Provide tissues, no-touch disposal receptacles, and soap and water in the center (if not readily available, use alcohol-based hand sanitizer that is at least 60% alcohol). Ensure adequate supplies are maintained and place hand sanitizers in multiple locations.
 - Place posters that encourage hand hygiene to help stop the spread of COVID-19 at the entrance to your workplace and in other areas where they are likely to be seen.
 - Discourage handshaking – encourage the use of other non-contact methods of greeting.
 - Direct employees to visit CDC website for information on coughing and sneezing etiquette and handwashing.

Public Health Guidance for **VULNERABLE WORKERS**

(continued)



Engineering & Environmental Controls (continued)

Improve engineering controls and perform routine environmental cleaning. Consider the following:

- Perform routine environmental cleaning and disinfection.
 - Routinely disinfect all frequently touched surfaces frequently; Provide disinfectant wipes to wipe down keyboards, electronics, remote controls, etc.
 - For disinfection, most common EPA-registered household disinfectants should be effective. Follow the manufacturer's instructions for all cleaning and disinfection products.
- Ensure compliance with ADA and ADEA regulations; CDC and OSHA guidance for reducing workplace exposure for all employees should be followed.
- Consider installing physical barriers (plexiglass or plastic window) in locations where vulnerable workers work.
- Perform enhanced disinfection after suspected cases of COVID-19 have been in the facility. Close off areas used by the sick person, open outside doors and windows to increase air circulation, and wait up to 24 hours or as long as possible before cleaning to allow for respiratory droplets settle before cleaning and disinfecting .



Administrative Controls

Establish administrative controls while employees and visitors are onsite. Consider the following:

- Reopen only if business can ensure strict social distancing, proper cleaning and disinfecting requirements and protection of their workers and customers; vulnerable workers are recommended to shelter in place until Phase 3.
- Consider conducting routine, daily health checks (e.g., temperature and symptom screening) of all employees.
- Encourage employees who are sick to stay at home; implement flexible sick leave and other flexible policies and practices, such as telework, if feasible.
- Monitor absenteeism of employees and create a roster of trained back-up staff.
- Create and test communication systems for employees for self-reporting and notification of exposures and closures.
- Cancel all non-essential travel and consider resuming non-essential travel in accordance with state and local regulations and guidance.



Personal Protective Equipment (PPE)

Require the appropriate type of PPE for employees and customers. Consider the following:

- Wear cloth face coverings; face shields as necessary.

REFERENCES

MI Safe Start: A plan to re-engage Michigan's economy. Retrieved from:

https://www.michigan.gov/documents/whitmer/MI_SAFE_START_PLAN_689875_7.pdf

Public Health Principles for a Phased Reopening During COVID-19: Guidance for Governors, John Hopkins Bloomberg School of Public Health, Center for Health Security, Retrieved from:

https://www.centerforhealthsecurity.org/our-work/pubs_archive/pubs-pdfs/2020/200417-reopening-guidance-governors.pdf

When and How to Reopen After COVID-19. Resolve to save Lives, Retrieved from:

https://preventepidemics.org/wp-content/uploads/2020/04/COV020_WhenHowLoosenFaucet_v4.pdf

When and How to Close due to COVID-19 Spread. Resolve to Save Lives, Retrieved from:

https://preventepidemics.org/wp-content/uploads/2020/04/COV020_WhenHowTightenFaucet_v3.pdf

Gottlieb S, et al. (2020, March) National Coronavirus Response: A Road Map to Reopening. American Enterprise Institute, Retrieved from: <https://www.aei.org/wp-content/uploads/2020/03/National-Coronavirus-Response-a-Road-Map-to-Recovering-2.pdf>

Frieden T, et al (2020, April). Box It In: Rapid Public Health Action Can Box in COVID-19 and Reopen Society. Resolve to Save Lives, Retrieved from:

https://preventepidemics.org/wp-content/uploads/2020/04/COV035_BoxItInBriefingDoc.pdf

RESOURCES

<u>Page</u>	<u>Resources</u>
78	COVID-19 Self Monitoring Booklet
86	Cleaning & Disinfection After Suspected or Confirmed COVID-19 Exposure
88	Use of Cloth Face Coverings to Help Slow Spread of COVID-19



CARE: **Check and Record Every Day**

May 2020

Introduction

During a time of sustained community spread of coronavirus disease 2019 (COVID-19), all individuals are at some risk for exposure within the community. This booklet provides important information about monitoring yourself and your loved ones for symptoms of COVID-19. COVID-19 is a respiratory illness caused by a virus that can spread from person to person.

All individuals are at some risk for exposure within the community. Take these steps to monitor your health:

1. Take your temperature with a thermometer two times a day and watch for cough or difficulty breathing (see instructions in this booklet).
2. Practice everyday preventive actions to reduce your risk of getting or spreading illness (see below).
3. Practice social distancing by keeping your distance from others (about 6 feet or 2 meters) and limit your activities in public.
4. If you get sick with fever, cough, or trouble breathing, follow instructions on page 3.

Your local health department may have specific instructions for you to follow that may be more restrictive than described above. If you are found to be a close contact of a confirmed COVID-19 case, you will be contacted by your local health department.

Practice Everyday Preventive Actions

The Centers for Disease Control and Prevention (CDC) recommends several actions for preventing the spread of respiratory illnesses, like COVID-19. It is a good habit to practice everyday preventive actions at all times.



If you have a medical emergency, call 911. If you develop symptoms, contact your health care provider to determine if you need to go for testing. Contact your provider before you leave so they can plan for your arrival. If you do not have a health care provider, contact LCHD. Testing sites are changing daily.

Check your Health and Record Every Day

COVID-19 is spreading throughout our community. If you have been exposed to a person with COVID-19, it may take between 2 to 14 days to know if you will get sick. It is important to check your health two times each day during this time of sustained community spread. Follow the steps below to check and record your health.

Step 1: Do health checks every morning and every night.

- Take your temperature.
- In addition to fever, be alert for any other symptoms of COVID-19, including:
 - New or worsening cough
 - Shortness of breath or difficulty breathing
 - Chills
 - Sore throat
 - Muscle pain
 - New loss of taste or smell
 - Gastrointestinal symptoms like nausea, vomiting, or diarrhea (less common)
- Write your temperature and any symptoms in the log included in this booklet.

Step 2: If you have a fever (fever is 100.4° F/38° C or higher), cough, or trouble breathing:

1. Do not go out in public.
2. Call your health care provider to inform them of your symptoms – call ahead before you go to a doctor's office or urgent care. If they recommend COVID-19 testing, you can call the Livingston County Health Department (LCHD) for up-to-date testing locations at 517-546-9850.
3. Avoid contact with others.
4. Stay home while you are sick, except to seek medical care.
5. Cover your mouth and nose with a tissue or your sleeve (not your hands) when coughing or sneezing.
6. Wash hands often with soap and water for at least 20 seconds to avoid spreading the virus to others.
7. Wash your hands with soap and water immediately after coughing, sneezing, or blowing your nose. If soap and water are not available, you can use an alcohol-based hand sanitizer that contains 60%-95% alcohol. Always wash hands with soap and water if hands are visibly dirty.

If you have a medical emergency, call 911. If you develop symptoms, contact your health care provider to determine if you need to go for testing. Contact your provider before you leave so they can plan for your arrival. If you do not have a health care provider, contact LCHD. Testing sites are changing daily.

Before you Take your Temperature

- Wait 30 minutes after eating, drinking, or exercising.
- Wait at least 6 hours after taking medicines that can lower your temperature, like:
 - Acetaminophen* (also called Tylenol)
 - Ibuprofen*
 - Aspirin*

*Check with your health care provider for dosage and frequency for any fever-reducing medications.

How to Take your Temperature



1. Turn the thermometer on by pressing the button near the screen.



2. Hold the tip of the thermometer under your tongue until it beeps. Do not bite the thermometer.



3. Read your temperature on the screen. If your temperature is 100.4° F/38° C or higher, you have a fever.



4. Write your temperature on the 14-day Symptom and Temperature Log in this booklet.



5. Clean your thermometer with soap and water and dry it well.

If you have a medical emergency, call 911. If you develop symptoms, contact your health care provider to determine if you need to go for testing. Contact your provider before you leave so they can plan for your arrival. If you do not have a health care provider, contact LCHD. Testing sites are changing daily.

How to Use your Symptom and Temperature Log

Two times a day (morning and night), write down your temperature and any COVID-19 symptoms you may have: new or worsening cough, difficulty breathing, fever, sore throat, chills, muscle pain, and new loss of taste or smell. Less common symptoms include nausea, vomiting, and diarrhea.

1. Fill in the dates on the log, starting with Day 1 and ending with Day 30.
2. Start recording your temperature and symptoms. **Fever is 100.4 °F/38 °C or higher.**
 1. If you get sick, contact your health care provider. If you do not have a health care provider, you can call LCHD for up-to-date testing locations at 517-546-9850.
3. Print more copies of the Symptom and Temperature Log, as needed. This is an ongoing and quickly changing situation; you may need to monitor your health for more than 30 days.

DAY 1	Feb 3, 2020	AM	No Symptoms	97.4
		PM	No Symptoms	98.6
DAY 2	Feb 4, 2020	AM	No Symptoms	97.9
		PM	No Symptoms	98.2
DAY 3	Feb 5, 2020	AM	No Symptoms	98.5
		PM	No Symptoms	98.7
DAY 4	Feb 6, 2020	AM	No Symptoms	98.3
		PM	No Symptoms	97.6
DAY 5	Feb 7, 2020	AM	No Symptoms	98.2
		PM	Mild cough	99.6

If you have a medical emergency, call 911. If you develop symptoms, contact your health care provider to determine if you need to go for testing. Contact your provider before you leave so they can plan for your arrival. If you do not have a health care provider, contact LCHD. Testing sites are changing daily.

Symptom and Temperature Log

DAY	DATE	SYMPTOMS	TEMPERATURE
DAY 1	_____	AM	
		PM	
DAY 2	_____	AM	
		PM	
DAY 3	_____	AM	
		PM	
DAY 4	_____	AM	
		PM	
DAY 5	_____	AM	
		PM	
DAY 6	_____	AM	
		PM	
DAY 7	_____	AM	
		PM	
DAY 8	_____	AM	
		PM	
DAY 9	_____	AM	
		PM	
DAY 10	_____	AM	
		PM	
DAY 11	_____	AM	
		PM	
DAY 12	_____	AM	
		PM	
DAY 13	_____	AM	
		PM	
DAY 14	_____	AM	
		PM	
DAY 15	_____	AM	
		PM	



If you get sick, contact your health care provider. If you do not have a health care provider, you can call LCHD for up-to-date testing locations at 517-546-9850.

If you have a medical emergency, call 911. If you develop symptoms, contact your health care provider to determine if you need to go for testing. Contact your provider before you leave so they can plan for your arrival. If you do not have a health care provider, contact LCHD. Testing sites are changing daily.

Symptom and Temperature Log

DAY	DATE	SYMPTOMS	TEMPERATURE
DAY 16	_____	AM	
		PM	
DAY 17	_____	AM	
		PM	
DAY 18	_____	AM	
		PM	
DAY 19	_____	AM	
		PM	
DAY 20	_____	AM	
		PM	
DAY 21	_____	AM	
		PM	
DAY 22	_____	AM	
		PM	
DAY 23	_____	AM	
		PM	
DAY 24	_____	AM	
		PM	
DAY 25	_____	AM	
		PM	
DAY 26	_____	AM	
		PM	
DAY 27	_____	AM	
		PM	
DAY 28	_____	AM	
		PM	
DAY 29	_____	AM	
		PM	
DAY 30	_____	AM	
		PM	



If you get sick, contact your health care provider. If you do not have a health care provider, you can call LCHD for up-to-date testing locations at 517-546-9850.

If you have a medical emergency, call 911. If you develop symptoms, contact your health care provider to determine if you need to go for testing. Contact your provider before you leave so they can plan for your arrival. If you do not have a health care provider, contact LCHD. Testing sites are changing daily.

Resources

Livingston County Health Department (LCHD):

<https://www.livgov.com/health/ph/Pages/COVID19.aspx>

Michigan Department of Health and Human Services (MDHHS):

<https://www.michigan.gov/coronavirus>

Centers for Disease Control and Prevention (CDC):

<https://www.cdc.gov/coronavirus/2019-ncov/index.html>

World Health Organization (WHO):

<https://www.who.int/emergencies/diseases/novel-coronavirus-2019>



LIVINGSTON COUNTY Health Department

2300 E Grand River Ave., Suite 102
Howell, MI 48843

517-546-9850



www.LCHD.org

This resource is for informational purposes only and is not intended for self-diagnosis or as a substitute for consultation with a health care provider. For more information contact your health care provider or visit the Centers for Disease Control and Prevention at www.cdc.gov. The information provided within this guide has been adapted from the CDC's *CARE: Check and Record Everyday*, 2020.

If you have a medical emergency, call 911. If you develop symptoms, contact your health care provider to determine if you need to go for testing. Contact your provider before you leave so they can plan for your arrival. If you do not have a health care provider, contact LCHD. Testing sites are changing daily.

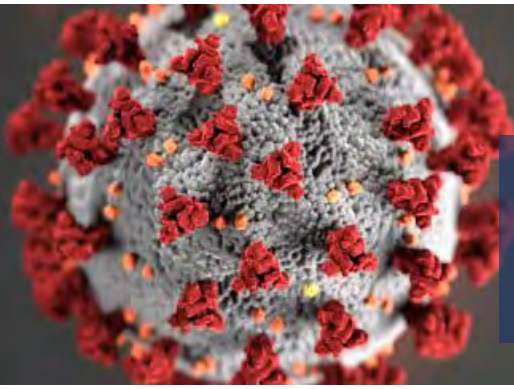

CLEANING & DISINFECTION

For Facilities After Suspected or Confirmed COVID-19 Exposure

Michigan.gov/Coronavirus

Timing and location of cleaning and disinfection of surfaces.

At a school, daycare center, office, or other facility that **does not house people overnight**:

It is recommended to close off areas used by the ill persons and wait as long as practical before beginning cleaning and disinfection to minimize potential for exposure to respiratory droplets. Open outside doors and windows to increase air circulation in the area. If possible, wait up to 24 hours before beginning cleaning and disinfection.

How to clean and disinfect.

Surfaces

If surfaces are dirty, they should be cleaned using a detergent or soap and water prior to disinfection.

For disinfection, diluted household bleach solutions, alcohol solutions with at least 70% alcohol, and most common EPA-registered household disinfectants should be effective.

- Diluted household bleach solutions can be used if appropriate for the surface. Follow manufacturer's instructions for application and proper ventilation.
- Check to ensure the product is not past its expiration date. Never mix household bleach with ammonia or any other cleanser.

- Unexpired household bleach will be effective against coronaviruses when properly diluted.

Prepare a bleach solution by mixing:

- Five tablespoons (1/3 cup) bleach per gallon of water, or
- Four teaspoons bleach per quart of water.

[Products with EPA-approved emerging viral pathogens claims](#) are expected to be effective against COVID-19 based on data for harder to kill viruses. Follow the manufacturer's instructions for all cleaning and disinfection products (e.g., concentration, application method and contact time, etc.).

Soft Surfaces

For soft (porous) surfaces such as carpeted floor, rugs, and drapes, remove visible contamination if present and clean with appropriate cleaners indicated for use on these surfaces. After cleaning:

- If the items can be laundered, launder items in accordance with the manufacturer's instructions using the warmest appropriate water setting for the items and then dry items completely. Otherwise, use products with the EPA-approved emerging viral pathogens claims [that are suitable for porous surfaces](#).

Linens, Clothing, and Other Items That Go in the Laundry

- Do not shake dirty laundry; this minimizes the possibility of dispersing virus through the air.
- Wash items as appropriate in accordance with the manufacturer's instructions. If possible, launder items using the warmest appropriate water setting for the items and dry items completely. Dirty laundry that has been in contact with an ill person can be washed with other people's items.
- Clean and disinfect hampers or other carts for transporting laundry according to guidance above for hard or soft surfaces.

Personal protective equipment (PPE) and hand hygiene considerations.

Cleaning staff should wear disposable gloves and gowns for all tasks in the cleaning process, including handling trash.

- Gloves and gowns should be compatible with the disinfectant products being used.
- Additional PPE might be required based on the cleaning/disinfectant products being used and whether there is a risk of splash.
- Gloves and gowns should be removed carefully to avoid contamination of the wearer and the surrounding area. Be sure to **clean hands** after removing gloves.
- Gloves should be removed after cleaning a room or area occupied by ill persons. [Clean hands](#) immediately after gloves are removed.
- Cleaning staff should immediately report breaches in PPE (e.g., tear in gloves) or any potential exposures to their supervisor.

Cleaning staff and others should clean hands often.

Clean hands often including immediately after removing gloves and after contact with an ill person, by washing hands with soap and warm water for 20 seconds. If soap and warm water are not available and hands are not visibly dirty, an alcohol-based hand sanitizer that contains at least 60% alcohol may be used. However, if hands are visibly dirty, always wash hands with soap and warm water.

Follow normal preventive actions while at work and home, including cleaning hands and avoiding touching eyes, nose, or mouth. Additional key times to clean hands include:

- After blowing one's nose, coughing, or sneezing
- After using the restroom
- Before eating or preparing food
- After contact with animals or pets
- Before and after providing routine care for another person who needs assistance (e.g., a child)

Use of Cloth Face Coverings to Help Slow the Spread of COVID-19

How to Wear Cloth Face Coverings

Cloth face coverings should—

- fit snugly but comfortably against the side of the face
- be secured with ties or ear loops
- include multiple layers of fabric
- allow for breathing without restriction
- be able to be laundered and machine dried without damage or change to shape

CDC on Homemade Cloth Face Coverings

CDC recommends wearing cloth face coverings in public settings where other social distancing measures are difficult to maintain (e.g., grocery stores and pharmacies), **especially** in areas of significant community-based transmission.

CDC also advises the use of simple cloth face coverings to slow the spread of the virus and help people who may have the virus and do not know it from transmitting it to others. Cloth face coverings fashioned from household items or made at home from common materials at low cost can be used as an additional, voluntary public health measure.

Cloth face coverings should not be placed on young children under age 2, anyone who has trouble breathing, or is unconscious, incapacitated or otherwise unable to remove the cloth face covering without assistance.

The cloth face coverings recommended are not surgical masks or N-95 respirators. Those are critical supplies that must continue to be reserved for healthcare workers and other medical first responders, as recommended by current CDC guidance.

Should cloth face coverings be washed or otherwise cleaned regularly? How regularly?

Yes. They should be routinely washed depending on the frequency of use.

How does one safely sterilize/clean a cloth face covering?

A washing machine should suffice in properly washing a cloth face covering.

How does one safely remove a used cloth face covering?

Individuals should be careful not to touch their eyes, nose, and mouth when removing their cloth face covering and wash hands immediately after removing.

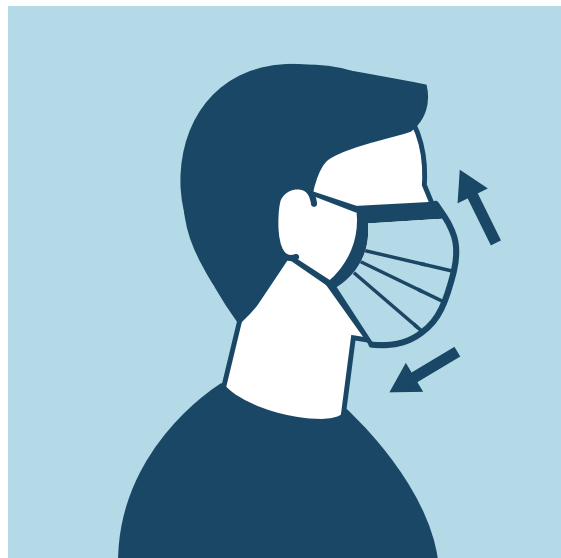

Sewn Cloth Face Covering

Materials

- Two 10"x6" rectangles of cotton fabric
- Two 6" pieces of elastic (or rubber bands, string, cloth strips, or hair ties)
- Needle and thread (or bobby pin)
- Scissors
- Sewing machine

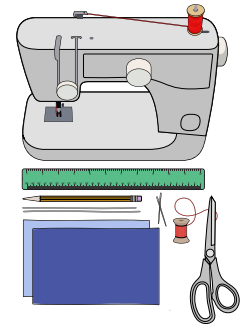

Tutorial

1. Cut out two 10-by-6-inch rectangles of cotton fabric. Use tightly woven cotton, such as quilting fabric or cotton sheets. T-shirt fabric will work in a pinch. Stack the two rectangles; you will sew the cloth face covering as if it was a single piece of fabric.

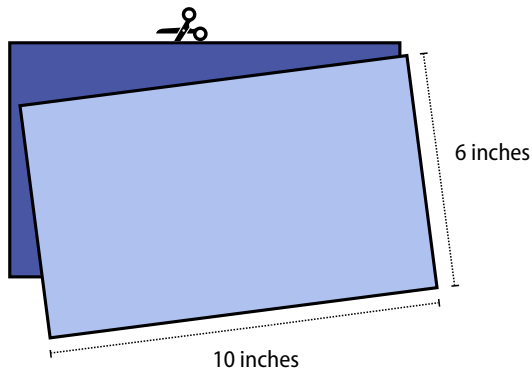

2. Fold over the long sides $\frac{1}{4}$ inch and hem. Then fold the double layer of fabric over $\frac{1}{2}$ inch along the short sides and stitch down.

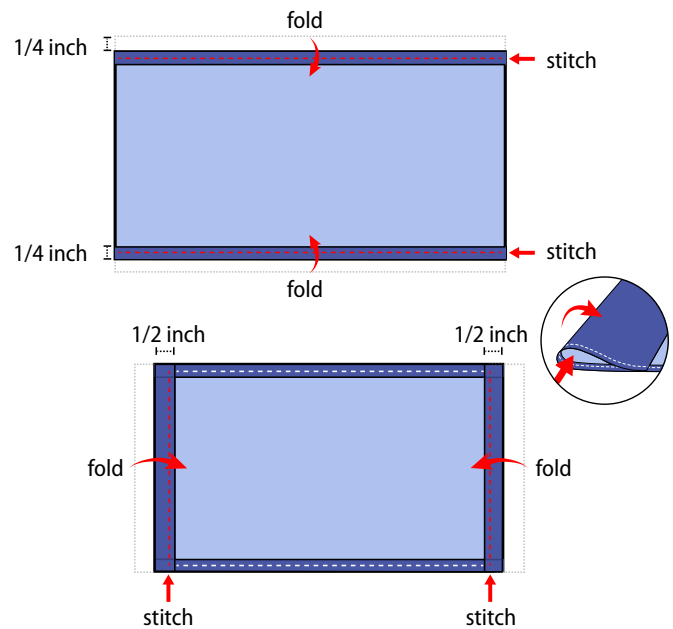

3. Run a 6-inch length of $\frac{1}{8}$ -inch wide elastic through the wider hem on each side of the cloth face covering. These will be the ear loops. Use a large needle or a bobby pin to thread it through. Tie the ends tight. Don't have elastic? Use hair ties or elastic head bands. If you only have string, you can make the ties longer and tie the cloth face covering behind your head.

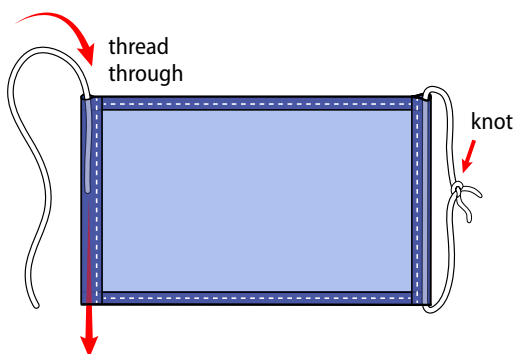

4. Gently pull on the elastic so that the knots are tucked inside the hem. Gather the sides of the cloth face covering on the elastic and adjust so the mask fits your face. Then securely stitch the elastic in place to keep it from slipping.

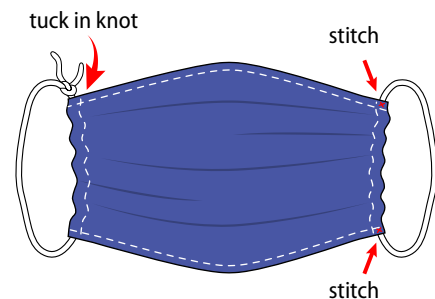

Quick Cut T-shirt Cloth Face Covering (no sew method)

Materials

- T-shirt
- Scissors

Tutorial

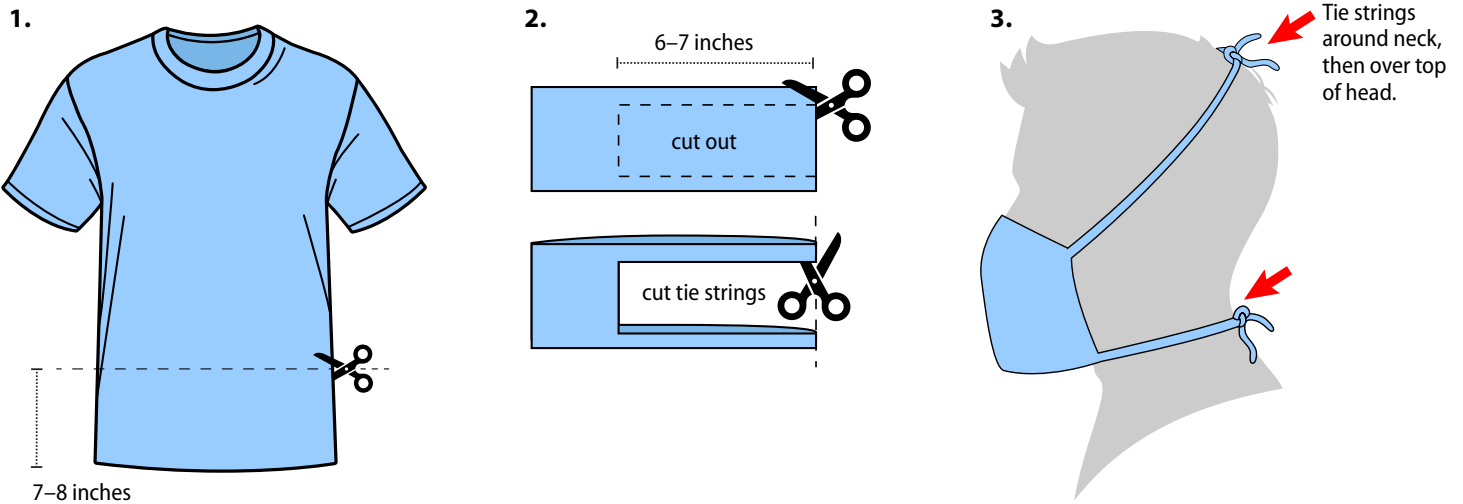

Bandana Cloth Face Covering (no sew method)

Materials

- Bandana (or square cotton cloth approximately 20"x20")
- Rubber bands (or hair ties)
- Scissors (if you are cutting your own cloth)

Tutorial

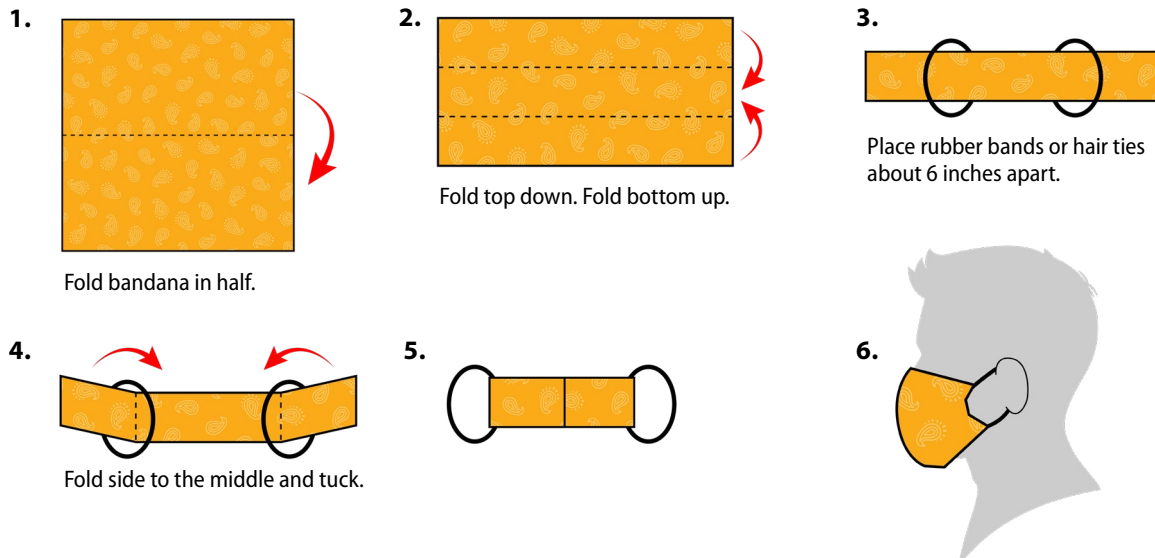

HANDOUTS FOR EMPLOYEES

<u>Page</u>	<u>Handouts for Employees</u>
92	MDHHS: Frequently Asked Questions for Face Coverings
95	MDHHS: COVID-19 Testing Process
96	MDHHS: When is it safe to leave home?
97	CDC: How to Protect Yourself and Others

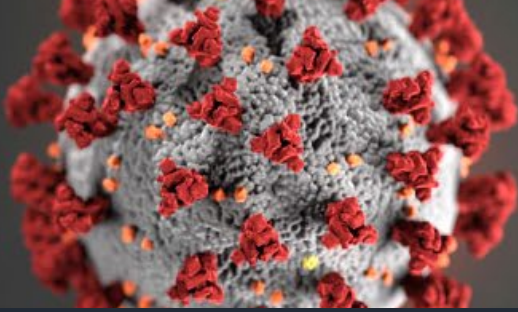

Face Coverings: Frequently Asked Questions

Michigan.gov/Coronavirus

Face Coverings: Frequently Asked Questions

The Michigan Department of Health and Human Services recommends that Michiganders wear a face covering when outside of their home to help stop the spread of coronavirus disease 2019 (COVID-19).

Wearing a face covering is an additional precaution we can take that may help stop the spread of COVID-19. The best way to keep from getting sick is to stay home as much as possible, practice social distancing – keep at least 6 feet of distance from others, and good hand hygiene.

What is a face covering?

- A face covering is any well-secured cloth (like a bandana or scarf) that covers your mouth and nose.
- A face covering is different from a surgical or N95 mask which must be reserved for healthcare workers.

Who should and should not wear a face covering?

Cloth face coverings **should not** be placed on:

- young children under age 2,
- anyone who has trouble breathing, is unconscious, incapacitated, and
- anyone otherwise unable to remove the mask without assistance.

Cloth face coverings **should** be worn by:

- All others when they need to be outside their home and within 6 feet of others.
- People who are sick should wear a face covering while at home if they cannot maintain at least 6 feet of distance from others.
- People who are sick and who need to leave home, such as to get urgent medical care, should always wear a face covering.

Do I need to wear a face covering all the time when outside my house?

- **If you are sick**, yes. Remember you must stay home if you are sick and only leave for essential medical care. Arrange for essential items, like groceries, to be delivered to you through a delivery service or through friends or family.
- **If you are not sick**, you should wear a face covering whenever you need to leave home and might be closer than 6 feet from others. Examples include using public transportation, riding in a taxi or car service, walking on a busy street, going to pharmacies and grocery stores, and going to the doctor or a hospital.
- **Essential workers** should also wear a face covering at work when they cannot maintain at least 6 feet of distance between themselves and others.

Do I need to wear a face covering when I am exercising?

No — as long as you maintain at least 6 feet from others.

People should only do exercises that allow them keep physical distance from others. Walking, running, and biking outside are good examples of activities that do not require shared equipment or close contact with others.

I was confirmed to have COVID-19 and am better now. Do I still need to wear a face covering?

Yes – everyone that is able should wear a face covering when outside of their home and it is not possible to maintain at least 6 feet of distance between others. Social distancing is still necessary, even when using a face covering.

We don't yet know how long the virus remains in a person's body, or whether it is possible to get sick again. Using facemasks in public and practicing social distancing is still important for people who were sick and recovered.

Remember if you had or may have had COVID-19, you should not leave the house except for essential medical care or to get essential needs until all the following are true:

- It has been at least 7 days since your symptoms started or since you tested positive for COVID-19 **and**
- You have been fever-free for the last 3 days without taking fever-reducing drugs such as Tylenol or ibuprofen **and**
- Your overall illness has improved (for example, when your cough or shortness of breath have improved).

Why is this being recommended now?

As we learn more about COVID-19, sometimes recommendations change. There is increasing evidence that people without symptoms may be able to spread the virus, and that droplets produced when breathing, speaking, or singing may spread COVID-19 from person to person.

This evidence informed the decision to recommend face coverings. The use of face coverings is one more simple tool that may help reduce the spread of the virus – especially from people who are infected and don't know it yet.

How often do I need to wash my face covering?

If you are using a cloth face covering, we recommend washing once a day by hand or machine using detergent. The face covering should be fully dry before using. You should have a couple of face coverings so you can rotate for washing.

Are there precautions I should take with my face covering?

- In taking on and off a face covering, you will likely touch your face. As such, please wash your hands with soap and warm water for at least 20 seconds. If soap and warm water are not

available, use an alcohol-based sanitizer that contains at least 60% alcohol every time before and after removing or putting on your mask.

- Do not put a used face covering in places where others can touch them or where germs trapped in your face covering can touch other surfaces, such as counter tops or your kitchen table.
- Do not throw your face covering loose in a bag or backpack. We recommend keeping a paper bag with you to store your face covering if you will be taking it off outside your house.

Is it possible to make your own face covering?

Yes! A face covering can be a scarf, bandana or other cloth. [Watch this video from the U.S. Surgeon General](#) to see ideas about creating a face covering with household items.

What is the best fabric for a mask?

Use tightly woven cotton, such as quilting fabric or cotton sheets.

Are medical grade masks such as N95 or surgical masks better than home made masks?

Medical grade masks need to be saved for use by health care providers only. Use of homemade masks for people with lower risk exposure is a good way to decrease the chance of exposure to COVID-19.

I think I have been exposed to COVID-19, what should I do?

Close Contacts

I live with or am caring for someone with COVID-19

Someone that has COVID-19 coughed or sneezed on me

I think my coworker has COVID-19

I think someone I know has COVID-19

You should self quarantine and monitor yourself for symptoms. The local health department may ask you to do so.*

You do not need to self quarantine, but it is a good idea to be vigilant and monitor yourself for symptoms.

Have you developed symptoms of respiratory illness such as **fever, cough, or shortness of breath**?

YES

NO

Are you having **severe symptoms** like difficulty breathing, persistent pain or pressure in the chest, new confusion or inability to arouse or bluish lips or face?

YES

NO

Seek immediate medical attention.

Contact your health care provider to discuss your symptoms.

Continue to monitor yourself for symptoms.

HOW DO I MONITOR MYSELF?

Pay attention for COVID-19 symptoms:

- **Fever**
- **Cough**
- **Shortness of Breath**

If you are concerned about your health, contact your health care provider.

If your doctor decides you should be tested for COVID-19,
your health care provider can order testing for you.

Health care provider takes a sample

Sample is sent to a laboratory for testing

Laboratory sends result to health care provider

Health care provider informs patient of result. The state health department will not provide results.

*Quarantine process for general public, does not specifically apply to health care workers.

When is it safe to leave home

if you have symptoms of COVID-19 or live with someone who does?

Employers can't retaliate against workers for taking time away from work under these circumstances.

File a complaint with MIOSHA . Learn more at Michigan.gov/MIOSHAc complaint.

For Me

I have been diagnosed with COVID-19.

I have developed one or more symptoms of COVID-19.

Stay home for 7 days after you were tested or developed symptoms.

After staying home for 7 days, have you been **symptom-free for 3 days**?

YES

NO

You may leave if you are symptom-free.

Stay home until 3 days have passed after all symptoms have stopped.

Close Contacts

I live with someone diagnosed with COVID-19.

I live with someone who has developed one or more symptoms of COVID-19.

Stay home for 14 days after your **last contact** with the sick person.
Monitor yourself for symptoms.

You may leave if you are symptom-free.

How do I monitor myself?



Pay attention for COVID-19 symptoms:

- **Fever**
- **Cough**
- **Shortness of breath**

If you are concerned about your health or develop symptoms, contact your health care provider or urgent care.



Should I wear a mask?

If you or your close contact is symptomatic and you must leave home, you should cover your nose and mouth with a homemade mask, scarf, bandana or handkerchief.

*Process for general public, does not specifically apply to workers at a health-care facility, first responders (e.g., police officers, fire fighters, paramedics), and prison employees.

How to Protect Yourself and Others

Know how it spreads



- There is currently no vaccine to prevent coronavirus disease 2019 (COVID-19).
- **The best way to prevent illness is to avoid being exposed to this virus.**
- The virus is thought to spread mainly from person-to-person.
 - » Between people who are in close contact with one another (within about 6 feet).
 - » Through respiratory droplets produced when an infected person coughs, sneezes or talks.
 - » These droplets can land in the mouths or noses of people who are nearby or possibly be inhaled into the lungs.
 - » Some recent studies have suggested that COVID-19 may be spread by people who are not showing symptoms.

Everyone should

Clean your hands often



- **Wash your hands** often with soap and water for at least 20 seconds especially after you have been in a public place, or after blowing your nose, coughing, or sneezing.
- If soap and water are not readily available, **use a hand sanitizer that contains at least 60% alcohol.** Cover all surfaces of your hands and rub them together until they feel dry.
- **Avoid touching your eyes, nose, and mouth** with unwashed hands.

Avoid close contact



- **Stay home if you are sick.**
- **Avoid close contact** with people who are sick.
- **Put distance between yourself and other people.**
 - » Remember that some people without symptoms may be able to spread virus.
 - » This is especially important for **people who are at higher risk of getting very sick.** www.cdc.gov/coronavirus/2019-ncov/need-extra-precautions/people-at-higher-risk.html



cdc.gov/coronavirus

Cover your mouth and nose with a cloth face cover when around others



- **You could spread COVID-19 to others** even if you do not feel sick.
- **Everyone should wear a cloth face cover when they have to go out in public**, for example to the grocery store or to pick up other necessities.
 - » Cloth face coverings should not be placed on young children under age 2, anyone who has trouble breathing, or is unconscious, incapacitated or otherwise unable to remove the mask without assistance.
- **The cloth face cover is meant to protect other people** in case you are infected.
- Do **NOT** use a facemask meant for a healthcare worker.
- Continue to **keep about 6 feet between yourself and others**. The cloth face cover is not a substitute for social distancing.

Cover coughs and sneezes



- **If you are in a private setting and do not have on your cloth face covering, remember to always cover your mouth and nose** with a tissue when you cough or sneeze or use the inside of your elbow.
- **Throw used tissues** in the trash.
- Immediately **wash your hands** with soap and water for at least 20 seconds. If soap and water are not readily available, clean your hands with a hand sanitizer that contains at least 60% alcohol.

Clean and disinfect



- **Clean AND disinfect frequently touched surfaces** daily. This includes tables, doorknobs, light switches, countertops, handles, desks, phones, keyboards, toilets, faucets, and sinks. www.cdc.gov/coronavirus/2019-ncov/prevent-getting-sick/disinfecting-your-home.html
- **If surfaces are dirty, clean them:** Use detergent or soap and water prior to disinfection.
- **Then, use a household disinfectant.** You can see a list of [EPA-registered household disinfectants here](#).

SIGNS FOR WORKPLACE

<u>Page</u>	<u>Signs for Workplace</u>
100	CDC: Germs all around you
101	CDC: Stop the Spread of Germs
102	CDC: Feeling Sick?
103	Face Coverings Must Be Worn

GERMS

are all around you.



Stay healthy.
Wash your hands.

Stop the Spread of Germs

Help prevent the spread of respiratory diseases like COVID-19.

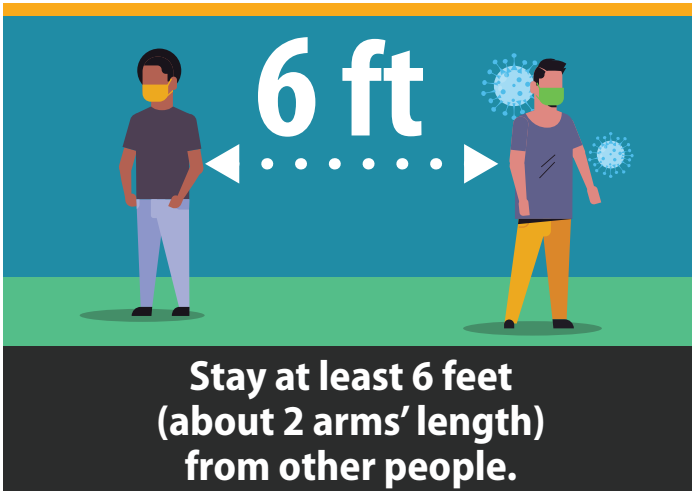

[cdc.gov/coronavirus](https://www.cdc.gov/coronavirus)



Feeling Sick?

Stay home when you are sick!

If you feel unwell or have the following symptoms
please leave the building and contact your health care provider.
Then follow-up with your supervisor.

DO NOT ENTER if you have:



FEVER

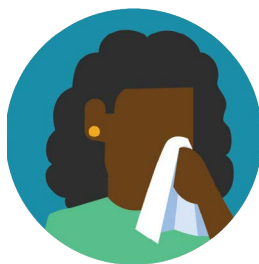

COUGH

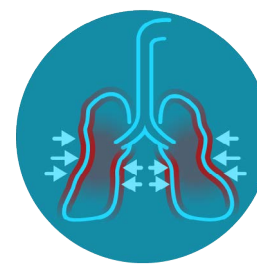

**SHORTNESS
OF BREATH**



cdc.gov/CORONAVIRUS



Attention:

Face masks/coverings required.

**Do not enter if you are sick!
(Fever, cough, shortness of breath)**





LIVINGSTON COUNTY Health Department



**2300 E. Grand River Ave.,
Howell, MI. 48843**

517-546-9850 | www.LCHD.org | [Facebook.com/myLCHD](https://www.facebook.com/myLCHD)

LCHD is committed to providing equitable, culturally competent care to all individuals served, regardless of race, age, sex, color, national origin, religion, height, weight, marital status, political affiliation, sexual orientation, gender identity, or disability.